



DA Series™ Tuckaway Liftgate

Read Before Installing

INSTALLATION MANUAL

For Models: DA25 • DA30

Ultron

Ultron Lift Inc.
12 Industrial St.
Toronto, ON M4G 1Y9 Canada
(416) 421-7987

Ultron Lift Corp.
190 Lewis St. • PO Box 6126
Buffalo, NY 14240-6126 USA
(716) 853-7994
800-289-1335

www.ultronlift.com

For Your Safety

This Manual follows the Guidelines set forth in ANSI Z535.4-1998 for alerting you to possible hazards and their potential severity.



This is the safety alert symbol. This manual uses this symbol to alert you to potential personal injury hazards. Obey all safety messages that follow this symbol to avoid possible injury or death.



DANGER indicates an imminently hazardous situation which, if not avoided, will result in death or serious injury.



WARNING indicates a potentially hazardous situation which, if not avoided, could result in death or serious injury.



CAUTION indicates a potentially hazardous situation which, if not avoided, may result in minor or moderate injury.



CAUTION used without the safety alert symbol indicates a potentially hazardous situation which, if not avoided, may result in property damage.

Memo To The Installer



WARNING

1. Improper installation and use of this liftgate may result in serious injury or death
2. Make sure that you are properly trained and qualified before you install this liftgate.
3. Make sure you read and understand this manual before you install this liftgate.

Please call us if you have any questions during this installation.

- USA: 800-289-1335
- Canada: 416-421-7987
- Monday through Friday, 8 A.M. to 5 P.M., Eastern Time

We are committed to:

- Helping you install this liftgate safely and correctly
- Providing your customer with a durable, trouble-free, long-lasting liftgate

Remember, we're on your team!

Thank you for choosing our liftgates.

Sincerely,

Quick Response Team

Ultron Lift Corp./Inc.





WARNING

1. **READ AND UNDERSTAND** installation instructions for installing this liftgate.
2. Failure to follow all instructions may result in severe personal injury or death.
3. Do not attempt this installation if you are not a qualified trained welding technician with appropriate training in liftgate installation.
4. Do not install truck lights if you are not properly trained in truck electrical equipment.

1. NEVER stand under or near the liftgate when the liftgate is being raised or positioned for installation.
This liftgate can crush persons, causing death or severe injuries.
2. ALWAYS disconnect the truck's positive and negative battery cables to avoid damage to the truck's electrical system.
Follow the procedures in the Vehicle Owner Manual.
3. ALWAYS turn the Master Disconnect switch to OFF when leaving the truck unattended.
4. ALWAYS lock cab doors to prevent unauthorized use of the liftgate.
5. ALWAYS affix safety decals according to these instructions.
6. ALWAYS perform final inspection after installation.
7. ALWAYS read the Operator's Manual before testing or operating this liftgate.
8. ALWAYS inspect your installation and complete the Final Inspection Checklist after finishing the installation.
9. ALWAYS follow the procedures in this Manual to install the Master Disconnect Switch and the Circuit Breaker.
10. ALWAYS install the Master Disconnect Switch and Circuit Breaker before reconnecting the truck's battery cables.
11. NEVER install the Master Disconnect Switch and Circuit Breaker if you are not properly trained in truck electrical equipment.

TABLE OF CONTENTS

For Your Safety	1
Memo To The Installer	2
About This Liftgate	5
1. PREPARE FOR INSTALLATION	6
1.1 Before You Start	6
1.2 Check Mounting Requirements	7
1.3 Check For Parts.....	8
1.4 Tools Required.....	10
1.5 Prepare the Truck Body.....	11
2. ATTACH THE LIFTGATE	12
2.1 Install Floor Extension	12
2.2 Prepare Liftgate for Installation	14
2.4 Install Platform	15
3. INSTALL ELECTRICAL COMPONENTS	17
3.1 Install Master Disconnect Switch	17
3.2 Install the Circuit Breaker	19
3.3 Secure The Cables	21
3.4 Mount Control Switch	22
3.5 Wire Lights (Options 207-3 and 207-4 Only)	23
4. TEST THE LIFTGATE OPERATION	24
5. COMPLETE THE INSTALLATION	25
5.1 Complete Welding	25
5.2 Adjust Platform	26
5.3 Install Up-Stop	27
5.4 Install Opening Arm	28
5.5 Install Dock Bumpers (Optional)	29
5.6 Affix Warning Decals	30
5.7 Operator's Manual	31
5.8 Final Test	32
5.9 Inspect Your Installation and Document Your Inspection.....	33
Inspection Sheet	34

About This Liftgate

DESCRIPTION

The DA Series liftgate is a tuck-away style liftgate. This style liftgate is available in the capacities of 2,500 and 3,000 lbs. Tuck-away style liftgates have two platform sections which fold and tuck completely under the rear of the truck.

This liftgate should be used to transport stable loads. The platform is not a level ride. Use increased caution when operating.

This model is not capable of raising above the floor of the truck.

THEORY OF OPERATION

The DA tuck-away style liftgate is designed to lift cargo from the ground to the bed of the truck, or vice-versa. This style liftgate operates using a direct lift hydraulic system. A 12 volt battery provides power to the hydraulic power unit which in turn supplies hydraulic fluid to the hydraulic cylinder. Upon storage, the liftgate platform folds in upon itself and "tucks away" under the rear of the truck.

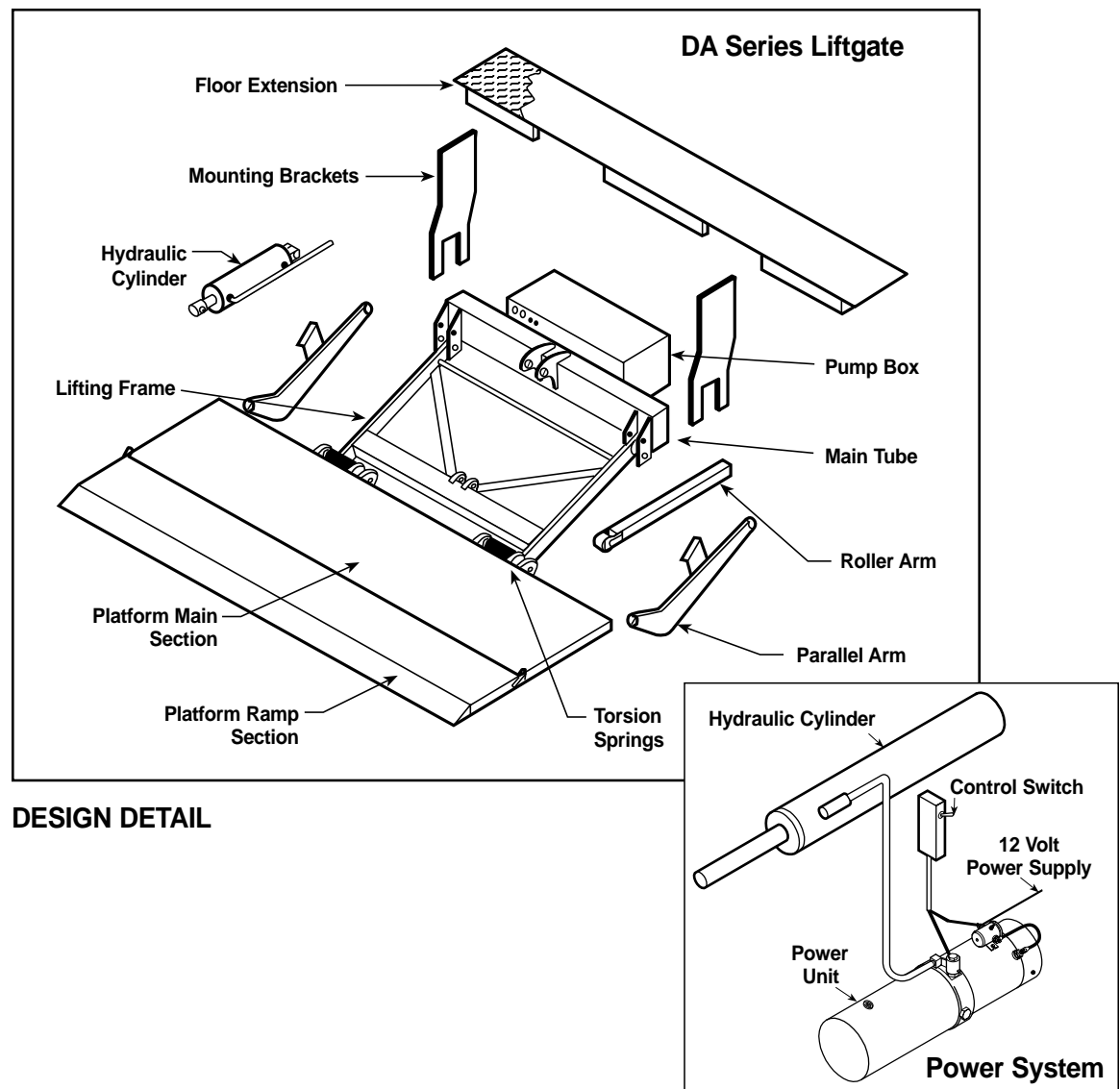

DESIGN DETAIL

1. PREPARE FOR INSTALLATION

1.1 Before You Start



WARNING

1. Liftgate can crush.
2. DO NOT INSTALL this liftgate if you do not understand all procedures.
3. Improper installation of the liftgate may result in severe personal injury or death.

Call Customer Service for assistance:

USA: 800-289-1335

Canada: 416-421-7987

STEP 1 Check the DA Model type (DA25, DA30).

STEP 2 Read this Installation Manual.

STEP 3 Become familiar with:

- The liftgate
- The components in the Electrical Component Kit
- The Safety Decal Kit

1.2 Check Mounting Requirements

- STEP 1** Determine the distance from the ground to floor level of truck. This is the bed height of the truck. The bed height of the truck is _____ inches.

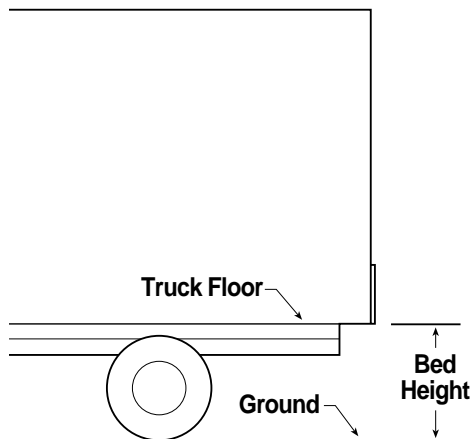

- STEP 2** Illustration below sets out correct mounting dimensions. Review illustration and your proposed installation to ensure that there will be no possible interference with tires. Minimum clearance required between liftgate housing (pump box) and truck tires is 5". (If clearance is less than 5", consider moving pump box)



Also check for possible interference from crossmembers, fuel tanks, chassis spring hangers, and U-bolts.

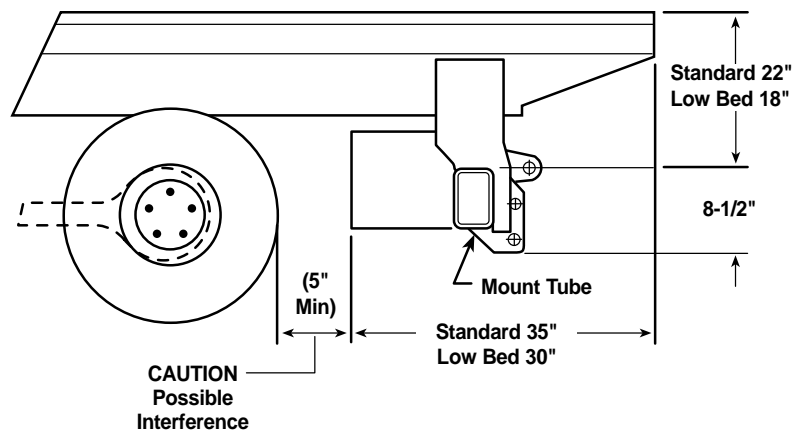

- STEP 3** Determine door requirements. Ensure truck body door does not interfere with installation or operation of liftgate. DA model liftgates cannot be installed with "barn" or "swing" type doors without extensive modification.

Consult Customer Service for assistance or if you are not sure your vehicle meets the requirements.

1.3 Check For Parts

STEP 1 Make sure you have all the parts listed below as well as all **Liftgate parts (See Design Detail, pg. 5)**. Check these parts and the liftgate assembly for shipping damage. Call Customer Service if any parts are missing or defective.
USA: 800-289-1335 • Canada: 416-421-7987

ELECTRICAL COMPONENT KIT

- Master Disconnect Switch with plate
- Circuit breaker
- 2 circuit breaker mounting screws
- 9 plastic nylon ties
- Two #2 x 3/8" copper lugs
- Two #2 x 1/4" copper lugs
- 4 heat-shrink tubes
- 9 frame clips

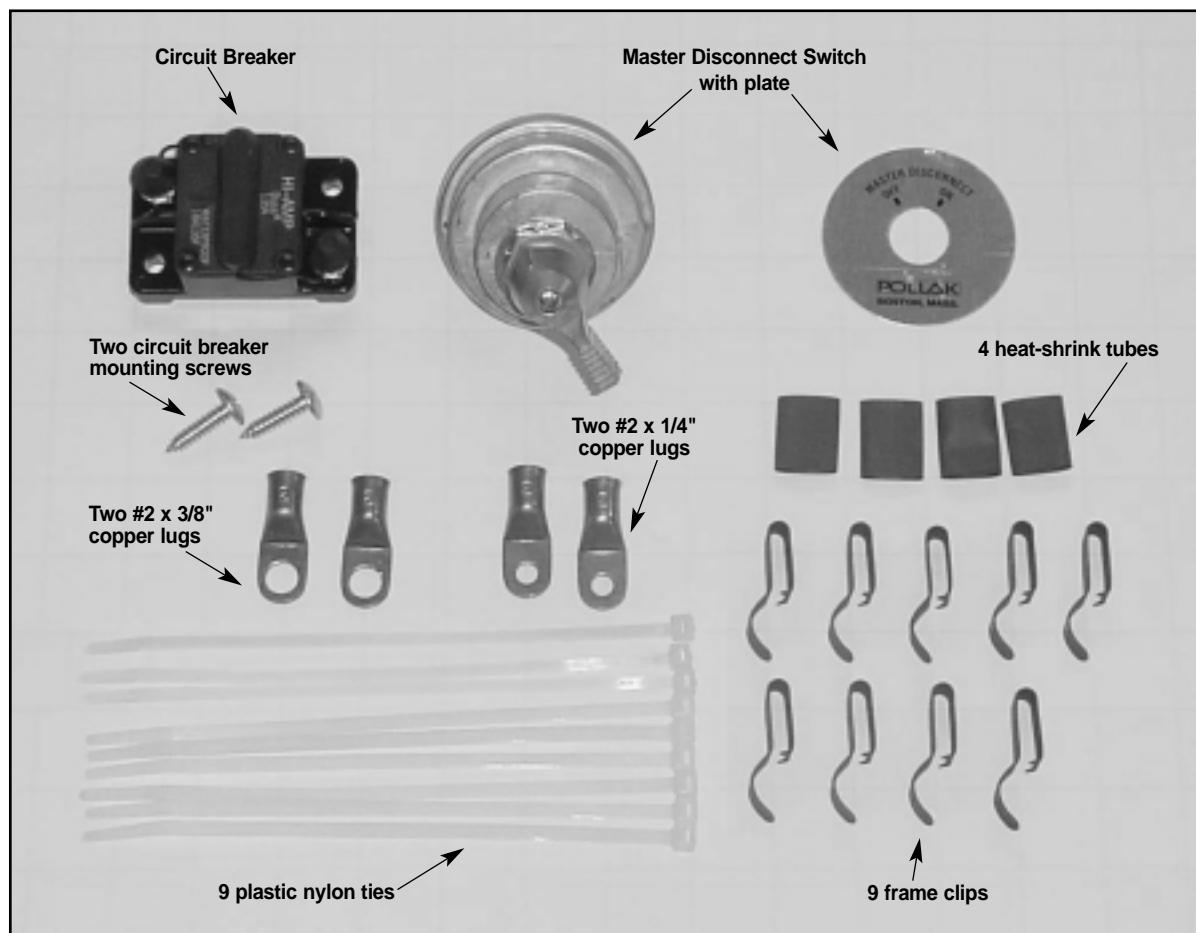

- STEP 2** Make sure you have all the parts listed below.
Check these parts for shipping damage.
Call Customer Service if any parts are missing or defective.
USA: 800-289-1335 • Canada: 416-421-7987

SAFETY DECAL KIT

- Urgent Warning: Elevating Gate Instructions
- 2 decals, Danger Message: Liftgate can crush.
- 1 decal, Warning Message: Keep people clear of liftgate while operating.
- 1 decal, Warning Message: Avoid riding liftgate.
- 1 decal, Safety Instruction: Turn Safety Latch
- 1 decal, Caution: Use this handle to open.
- 2 decals, Maximum Capacity

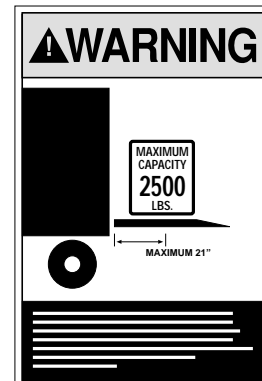
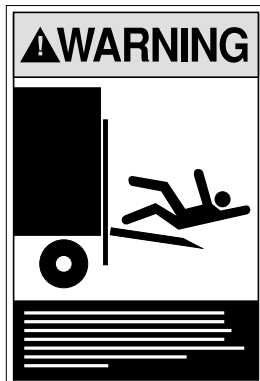
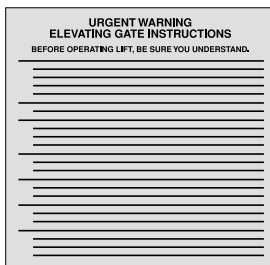

INSTALLATION MANUAL

OPERATOR'S MANUAL KIT

- Operator's Manual
- Warranty Registration Card

STEP 3 Check for shipping damage.

STEP 4 Put the Operator's Manual in the glove box.

STEP 5 Put decals in secure place for later installation.

1.4 Tools Required

STEP 1 Make sure you have the following tools, equipment, and materials available:

- Chalk or other marking device
- Wrenches
- Cutting torch
- Twelve 10" C-clamps
- Lifting device: floor jack, forklift, or crane
- Welding machine
- Tape measure
- Grease
- Pliers
- 2 pieces of channel (3" x 1-1/2" x 1/4" minimum)
- Heat shrink gun

1.5 Prepare the Truck Body

STEP 1 Remove lights and wiring harness from back of truck.

STEP 2 Remove rear step or any protrusions that would prevent floor extension from being mounted flush against truck bumper.

Note: To avoid alternator damage, some installations require disconnection of truck's electrical system before welding. Check vehicle's manual for specific recommendations.

STEP 3 Cut away or add to truck frame to obtain dimensions shown. Use diagram that matches your truck's bed height.

42" - 56" Bed Heights

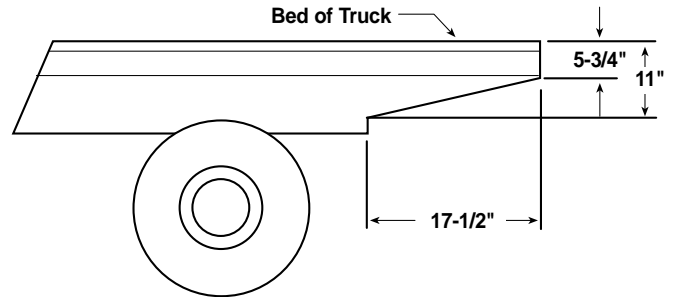

36" - 44" Bed Heights

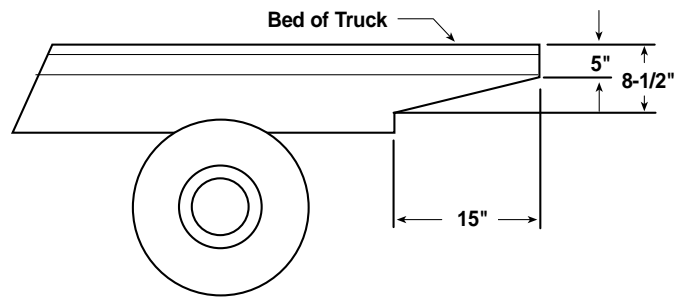

For 34" - 44" Bed Height Installations:

If it is not possible to obtain the 5" dimension shown, rear sill of the truck can be notched as specified by the chart and notching diagram.

Notching Chart

Model	Platform Width	A	B
DA25/30	72"	20-3/8"	35-1/2"
DA25/30	85"	20-3/8"	43-1/2"

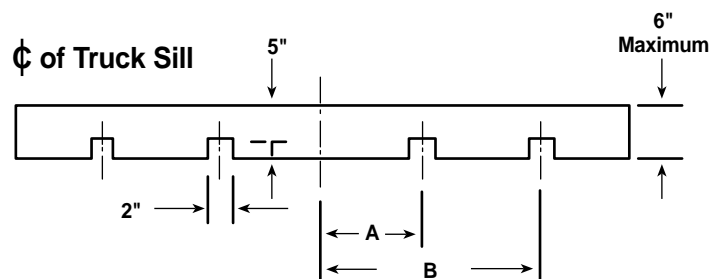

2. ATTACH THE LIFTGATE

2.1 Install Floor Extension



WARNING

1. Liftgate can crush people.
2. Keep people away from liftgate when positioning the liftgate.

STEP 1 Locate and mark center of floor extension and truck bed.

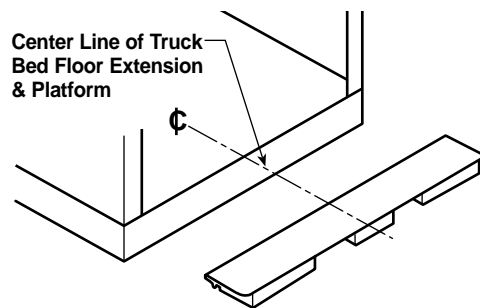

STEP 2 Tack weld or C-clamp two pieces of 3" channel on each end of floor extension, as shown, to support weight of floor extension.

Note! Your liftgate is assembled. The cables are prefastened to the liftgate.

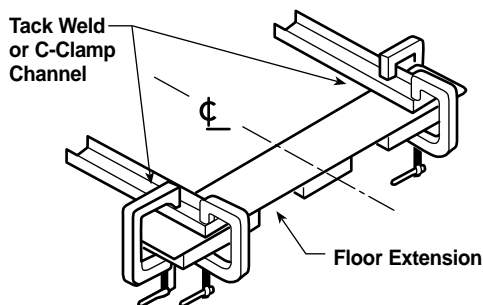

STEP 3 Center Floor Extension on rear of truck using a forklift or crane.



Make sure Floor Extension is flush, level and centered with mark previously made at center of truck floor and truck sill. This step is critical for proper dock bumper and platform installation.

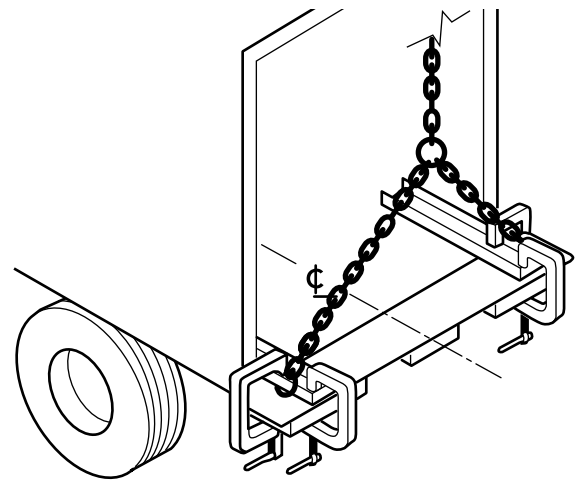

STEP 4 Weld floor extension to rear of truck with 3/8" x 2" fillet welds located above each gusset, latch support plate, and end cap.

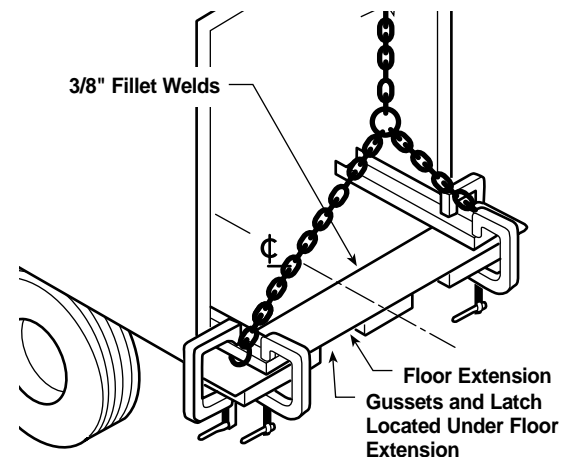

STEP 7 Place a 1/4" x 2" fillet weld at bottom of each gusset and around safety latch support plates.

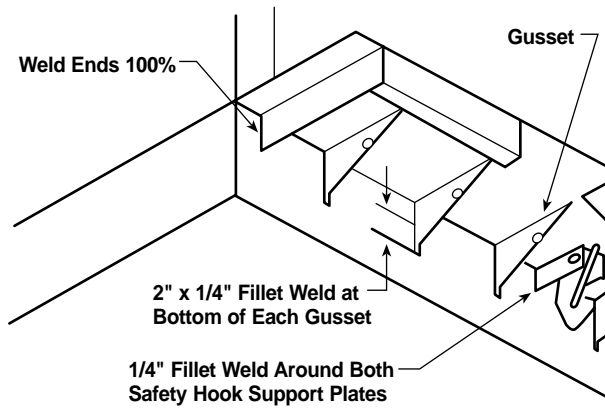

STEP 8 Remove channel from floor extension.

2.2 Prepare Liftgate for Installation

STEP 1 Unfold liftgate platform.

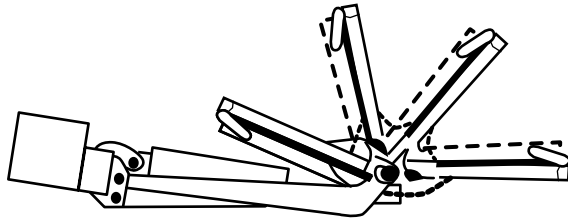

WARNING

Platform is heavy and can crush!

STEP 2 Lay the battery cable along the length of truck so power can be temporarily hooked up later in installation.

STEP 3 Put the electrical component kit aside for later installation.

2.3 Install Platform



CAUTION

Make sure that battery cables are disconnected before welding to avoid damaging the truck's electrical system.

- STEP 1** Using chain fall, fork lift, or overhead crane, raise platform to rear of truck. Make certain platform is flush, level, and centered with floor extension to ensure that safety hook aligns and works properly.

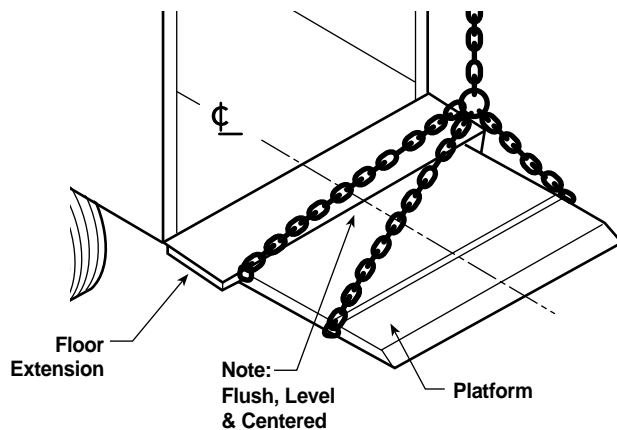

- STEP 2** Place two channels (3" x 1-1/2" x 1/4") on floor extension. Channels must extend to end of platform. C-clamp channels to floor extension and platform to hold platform parallel and level with floor extension as shown. Place a 3/16" spacer between edge of floor extension and platform, as shown.

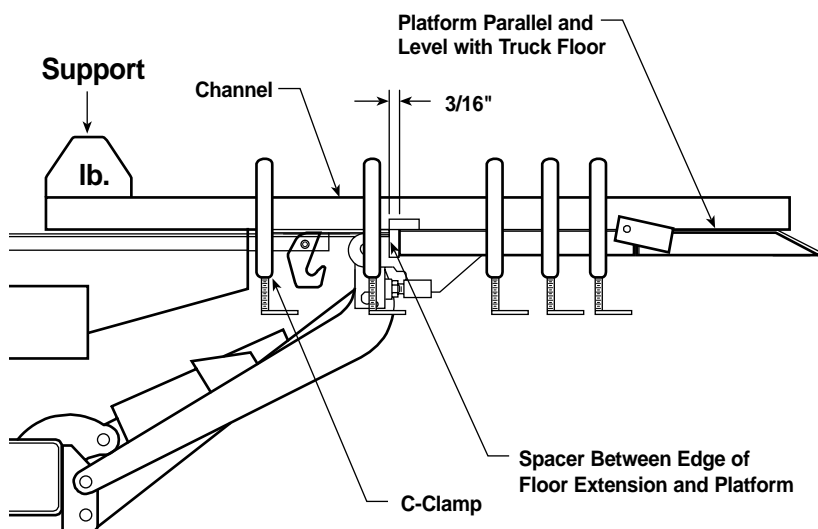

WARNING

Platform is heavy and can crush! Keep people away from liftgate when positioning the liftgate.

STEP 3 Cylinder locking angle will automatically locate mount tube at correct distance from truck floor. (we call this the "Installation Dimension"). Mount tube should be approximately 90 degrees to the truck chassis (+/- 5 degrees).

Installation Dimension: should be measured from top of truck bed to top of the middle of the mount tube. This distance should be dimension shown on the diagram below, +/-1" (Standard lift: 22"; Lowbed lift: 18"). If Installation Dimension is not correct, **call Customer Service.**

Note: Outer ends of mount tube may vary slightly. This is acceptable; do not force ends of mount tube to meet the Installation Dimension.

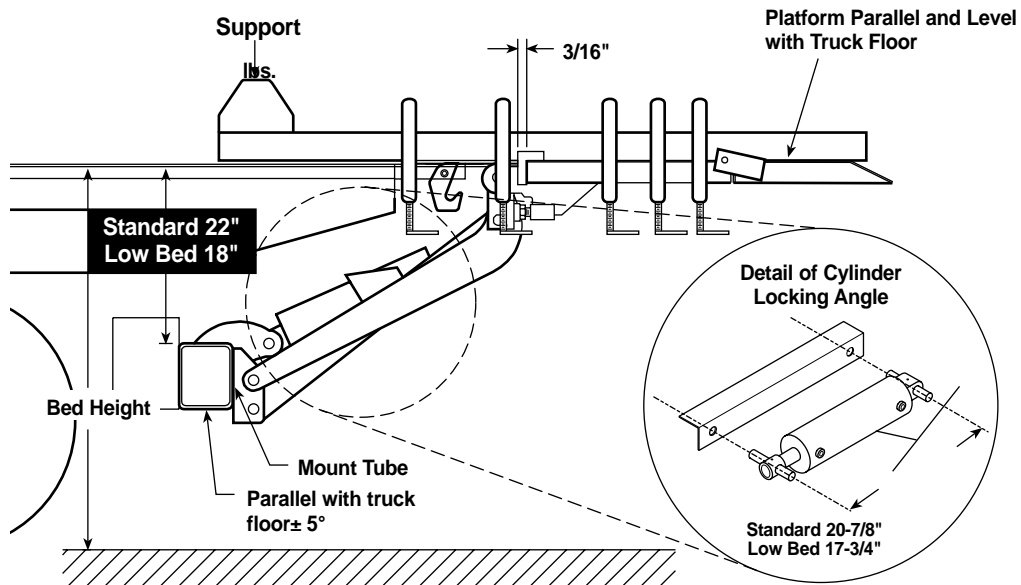



WARNING

Make sure jam nut on fine adjusting bolt is tightened to prevent bolt from loosening. If bolt loosens, platform may fall, creating risk of personal injury.

STEP 4 Weld mounting plates to truck chassis and mount tube with ten 3/8" x 1" fillet welds around the plates. Ensure the 3/16" spacer remains in place.

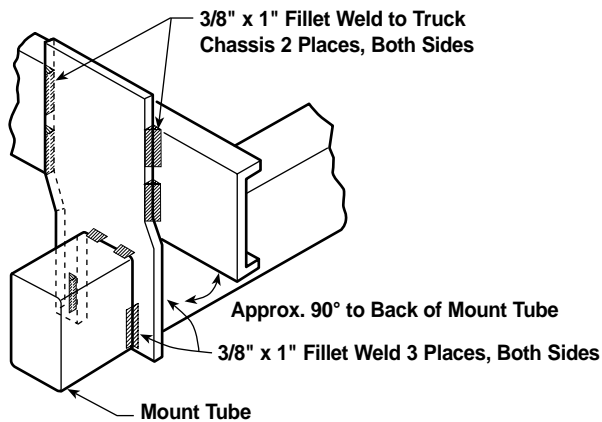

3. INSTALL ELECTRICAL COMPONENTS



WARNING

Do not attempt to install electrical components unless you are properly trained in truck electrical equipment. Improper installation of electrical components may result in severe personal injury or death.

3.1 Install Master Disconnect Switch



Install the Master Disconnect Switch and the Circuit Breaker that you received with your DEL liftgate.

If you use any other switch or circuit breaker, you will void your warranty.

STEP 1 Familiarize yourself with electrical components/layout in installation below. Refer back to this installation as needed during installation of electrical components.

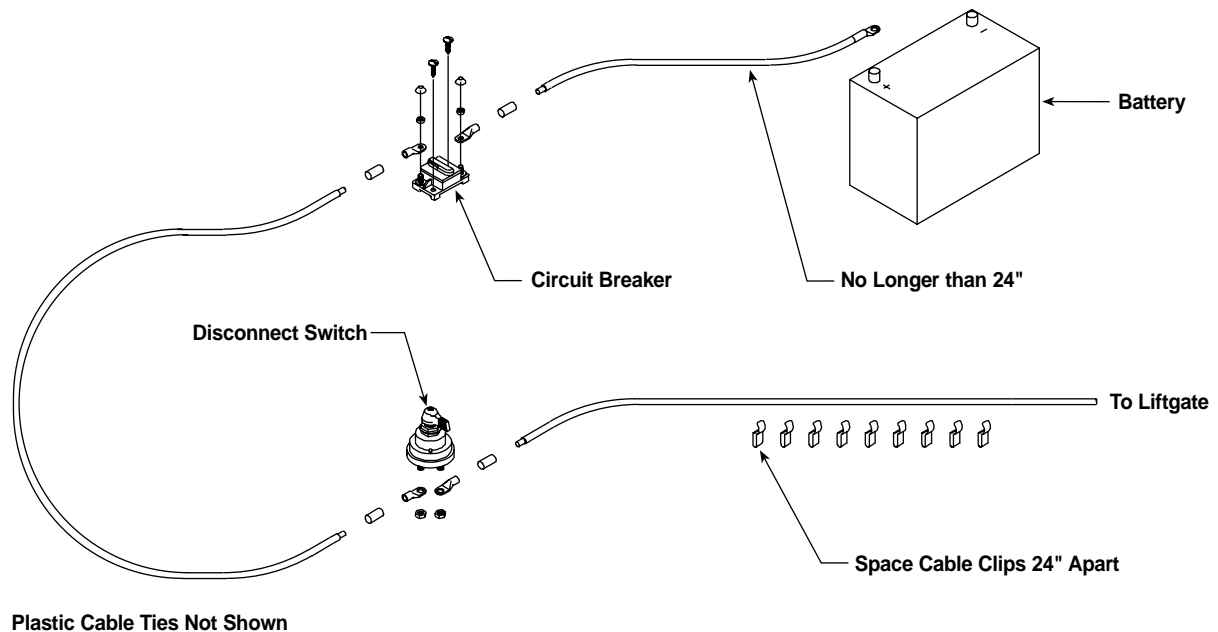

STEP 2 Find a place in the cab to install the Master Disconnect Switch.

The best location is:

- Accessible to the driver/operator
- and
- Secure from damage

STEP 3 Drill one 3/4" hole in the floor.

STEP 4 Remove the screw from the center of the handle on the Master Disconnect Switch.

STEP 5 Unscrew the large nut and remove the lock washer from the top of the switch.

STEP 6 Insert switch into hole from underneath the cab floor so the threaded part of the switch is visible.

STEP 7 Put the cover plate over the visible part (threaded part) of the switch.

STEP 8 Secure the nut and washer to the threaded part of the switch.

STEP 9 Reattach handle and cover plate.
Note! The handle and cover plate should be the only part of the switch visible.

STEP 10 Run the battery cable from the liftgate to the terminals on the Master Disconnect Switch.
Note! To avoid short circuits:
Route the cable away from heat sources, moving parts, and possible road contact.
Secure the cable under the truck every 24" with the plastic ties and wire clamps provided in the Electrical Component Kit.

STEP 11 Determine how long the battery cable should be to reach the terminals and cut it to that length.
Note! Measure before cutting!

STEP 12 Strip battery cable casing back 1/2".

STEP 13 Slide the shrink tube over the battery cable.

STEP 14 Crimp the battery terminal provided to the stripped end of the cable.

STEP 15 Slide the shrink tube into position centered over the terminal and battery cable seam.

STEP 16 Heat the shrink tube until the tube is sealed against terminal and battery cable casing.

STEP 17 Apply a protective coating of corrosion preventive compound to the connections.
Note! Terminal connections may corrode prematurely unless you apply the corrosion preventive compound.

3.2 Install the Circuit Breaker

STEP 1 Find a convenient location within 24" of the battery to install the Circuit Breaker. Location should be such that:

- Cable running from positive terminal of battery is no longer than 24".
- There is good protection against objects coming in contact with Circuit Breaker terminals and causing a short.
- There is easy access to the Circuit Breaker to reset it, when necessary.

STEP 2 Use the Circuit Breaker as a guide to drill pilot holes for the 1/4" sheet metal screws provided.

STEP 3 Screw the Circuit Breaker to the compartment wall.

STEP 4 Measure how long the battery cable should be to reach from the unconnected terminal on the Master Disconnect Switch to the AUX terminal on the Circuit Breaker.

STEP 5 Cut the battery cable to the correct length.
Note! Measure before cutting!

STEP 6 Run the battery cable from the unconnected terminal on the Master Disconnect Switch to the AUX terminal on the Circuit Breaker.

Note! To avoid short circuits:
Route the cable away from heat sources, moving parts, and possible road contact.
Secure the cable under the truck every 24" with the plastic ties and wire clamps provided in the Electrical Component Kit.

STEP 7 Strip battery cable casing back 1/2".

STEP 8 Slide the shrink tube over the battery cable.

STEP 9 Crimp the battery terminal provided to the stripped end of the cable.

STEP 10 Slide the shrink tube into position centered over the terminal and battery cable seam.

STEP 11 Heat the shrink tube until the tube is sealed against terminal and battery cable casing.

STEP 12 Apply a protective coating of corrosion preventive compound to the connections.

Note! Terminal connections may corrode prematurely unless you apply the corrosion preventive compound.

STEP 13 Measure how long the battery cable should be to reach from the BAT terminal on the Circuit Breaker to the positive side of the battery.

STEP 14 Cut the battery cable to the correct length.
Note! Measure before cutting!

STEP 15 Run the battery cable from the BAT terminal on the Circuit Breaker to the positive side of the battery.

Note! To avoid short circuits:

Route the cable away from heat sources, moving parts, and possible road contact.

Secure the cable under the truck every 24" with the plastic ties and wire clamps provided in the Electrical Component Kit.

STEP 16 Strip battery cable casing back 1/2".

STEP 17 Slide the shrink tube over the battery cable.

STEP 18 Crimp the battery terminal provided to the stripped end of the cable.

STEP 19 Slide the shrink tube into position centered over the terminal and battery cable seam.

STEP 20 Heat the shrink tube until the tube is sealed against terminal and battery cable casing.

STEP 21 Apply a protective coating of corrosion preventive compound to the connections.

Note! Terminal connections may corrode prematurely unless you apply the corrosion preventive compound.

STEP 22 Connect the positive and the negative leads to the battery.

3.3 Secure The Cables

STEP 1 Use the nylon ties included in your Electrical Component Kit to secure any cable running underneath the truck as detailed in Step 2 below.

Note! If the cable is not secured properly, the warranty is null and void.

STEP 2 Secure the cable every 24", keeping it away from:

- Moving parts
- Heat sources (exhaust)
- Road

3.4 Mount Control Switch

STEP 1 Control switch should be mounted to the rear door frame on the passenger side of the truck. Use the template below as a guide for drilling the switch mounting holes.

Note: Failure to mount the switch as specified will void the warranty on the liftgate.

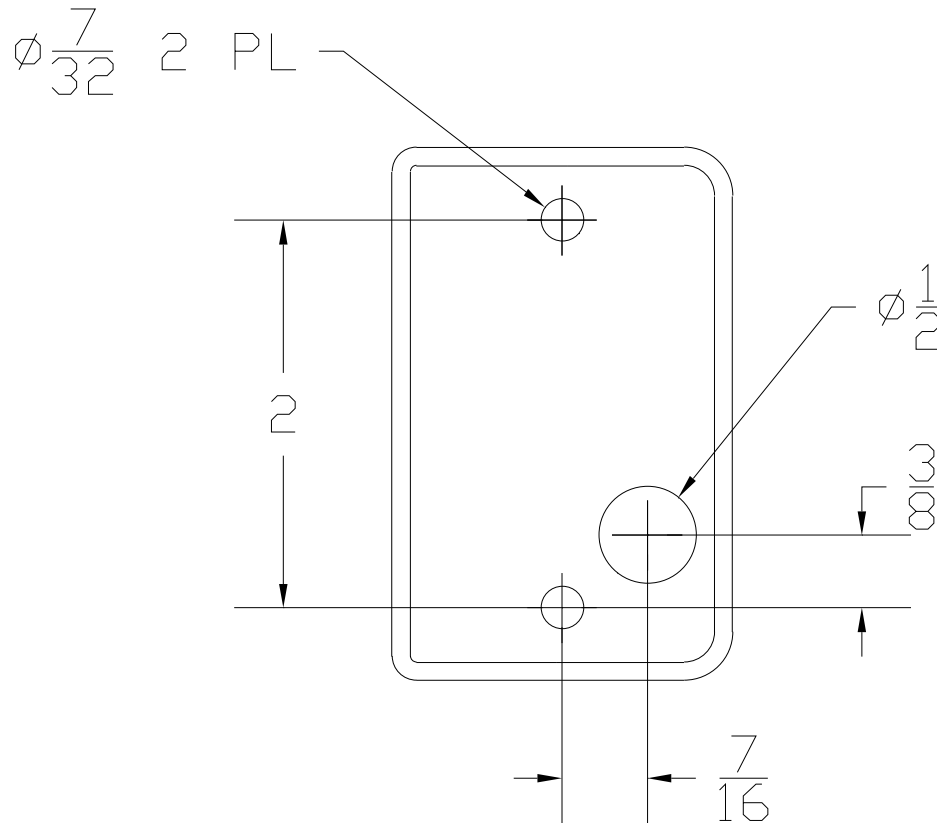

STEP 2 Route switch wire through door frame and reconnect to liftgate power unit.

STEP 3 Attach switch to door frame with $\frac{1}{4}$ "-20 x 1 $\frac{1}{4}$ " self tapping screws provided.

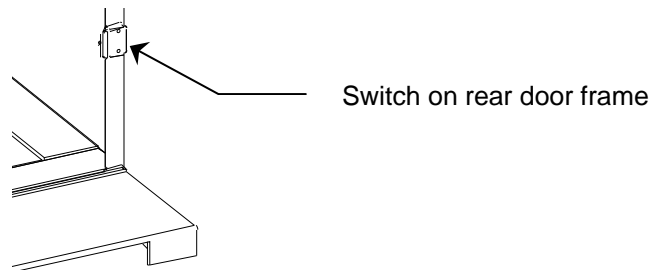

STEP 4 Secure control cable with clamps supplied to protect it from damage by the liftgate

3.5 Wire Lights (Options 207-3 and 207-4 Only)



All lights must be installed in accordance with all applicable DOT and other state, provincial, and federal regulations.

STEP 1 Using the **Wiring Schematic** as a guide, wire the mating plug and harness to the vehicle's wiring system.

Wiring Schematic

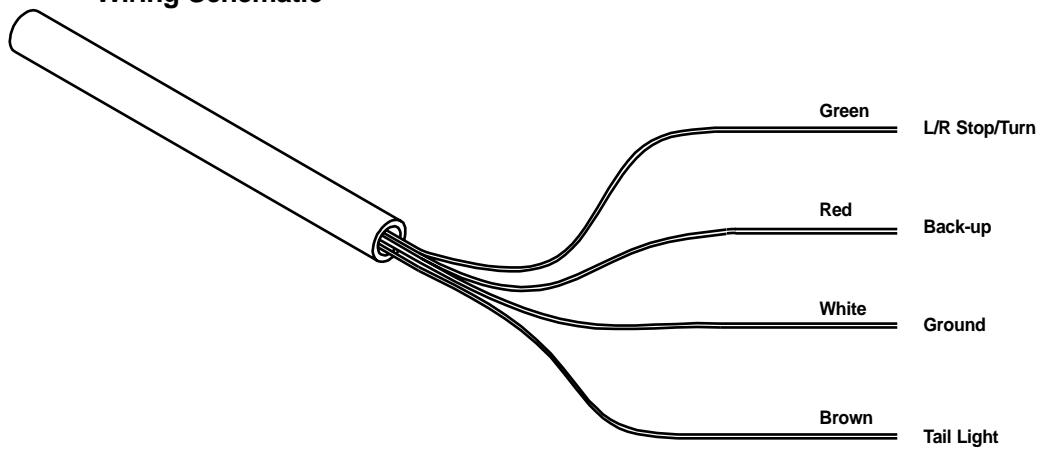

STEP 2 Make sure all lights operate properly after wiring.

4. TEST THE LIFTGATE OPERATION

STEP 1 Remove cylinder locking angle by cutting and removing nylon tie.

STEP 2 Remove tack welds between platform and floor extension. Remove all clamps and support channels. remove 3/16" spacer between edge of floor extension and platform.

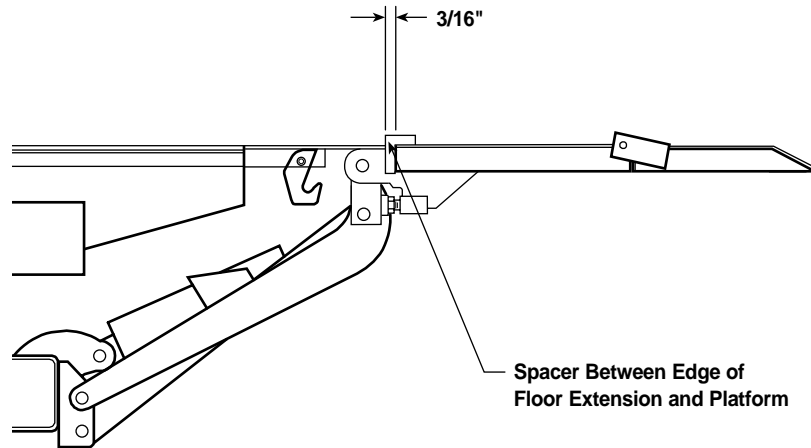

WARNING

Platform will drop suddenly 2" and stop when clamps are removed.

STEP 3 Run the liftgate through a complete cycle to ensure the unit operates properly. Check to ensure that top of platform is level with top of floor extension. Check to ensure the correct alignment and operation of the safety latch and bail.

Note: If liftgate does not operate, check all electrical components.

5. COMPLETE THE INSTALLATION

5.1 Complete Welding

STEP 1 Weld all sides of the mount plate 100% to truck chassis and mount tube.

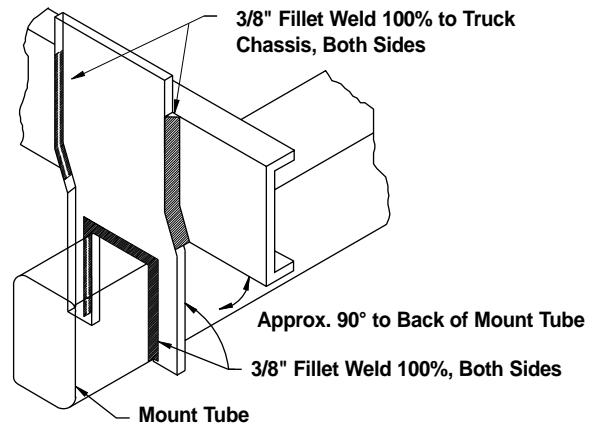

5.2 Adjust Platform

STEP 1 Lower the platform until the stop block hits the ground. If the platform is straight with the tip of the ramp touching the ground, as shown in Fig. 1, no adjustment is required. If the platform is sagging, as shown in Fig. 2, the fine adjusting bolt must be backed out until the platform is straight with the tip of the ramp touching the ground, as shown in Fig. 1.

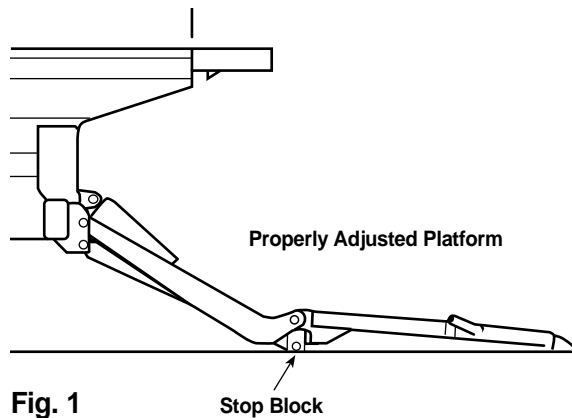

Fig. 1

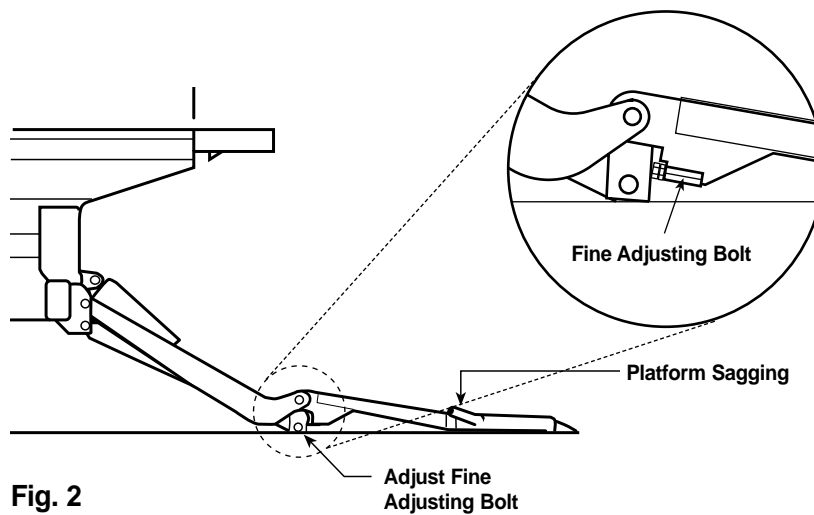

Fig. 2

Note: Always secure jam nut after making any adjustments.



WARNING

Make sure jam nut on fine adjusting bolt is tightened to prevent bolt from loosening. If bolt loosens, platform may fall, creating risk of personal injury.

5.3 Install Up-Stop

STEP 1 The up-stop prevents excessive movement of the platform when traveling. To install, fold platform to the stored position. Using the control button, raise the platform so the top edge of the adjuster bolt is approximately 1/8" from the bottom of the floor extension and safety hook has engaged the platform catch.

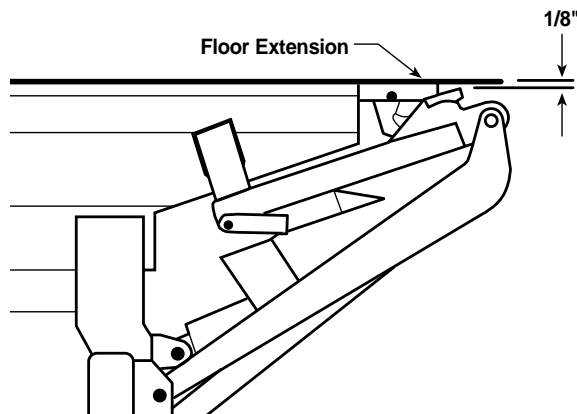

STEP 2 Position up-stop along outside of truck frame as shown. Only one up-stop in place. Before finishing welding, check to make sure up-stop does not interfere with opening or folding of the platform.

Note: Use up-stop supplied in the parts box.

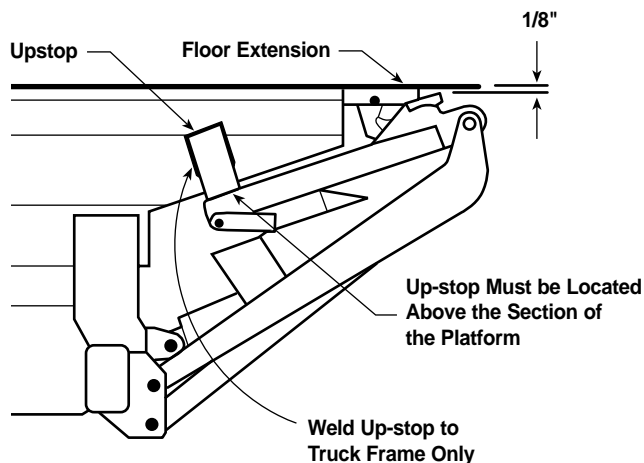

5.4 Install Opening Arm

STEP 1 Position roller at end of arm as indicated in chart. Roller on opening arm should ride on rest plate located on underside of platform extension.

Opening Arm Chart

Bed Height	A	B
Min. – Max.		
34" – 44"	1-1/4"	19"
44" – 50"	4"	22-1/2"
50" – 56"	0"	28"

Note: Dimensions in opening arm chart are for reference only. Actual location of opening arm can vary as long as platform opens and closes without interference with truck chassis.

STEP 2 Weld opening arm with two 1/4" x 3" fillet welds on passenger side of mount tube end plate. Back of platform extension should be approximately 75 degrees from ground when lowered.

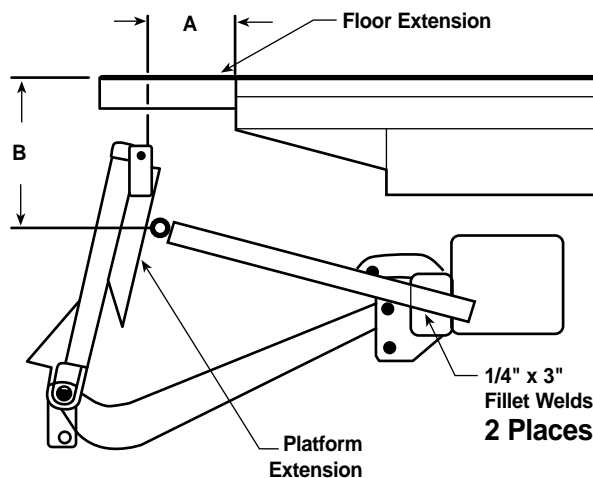

5.5 Install Dock Bumpers (Optional)

STEP 1 Position and weld dock bumper tubes against outside of right hand and left hand floor extension side plate.

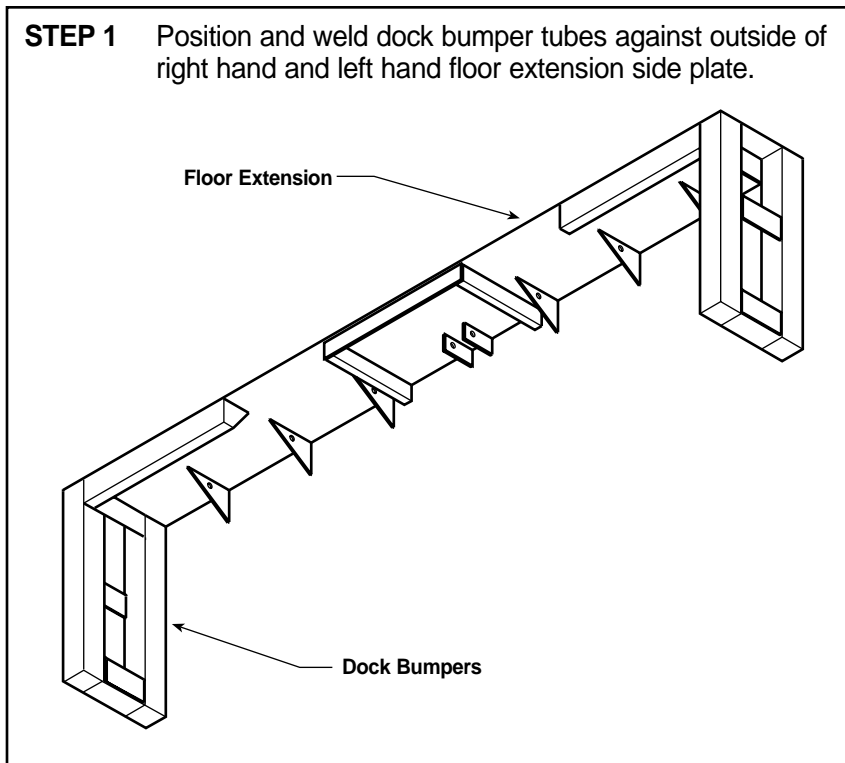

5.6 Affix Warning Decals

STEP 1 Apply the decals provided to their proper positions, following the figure below.

Decal Placement

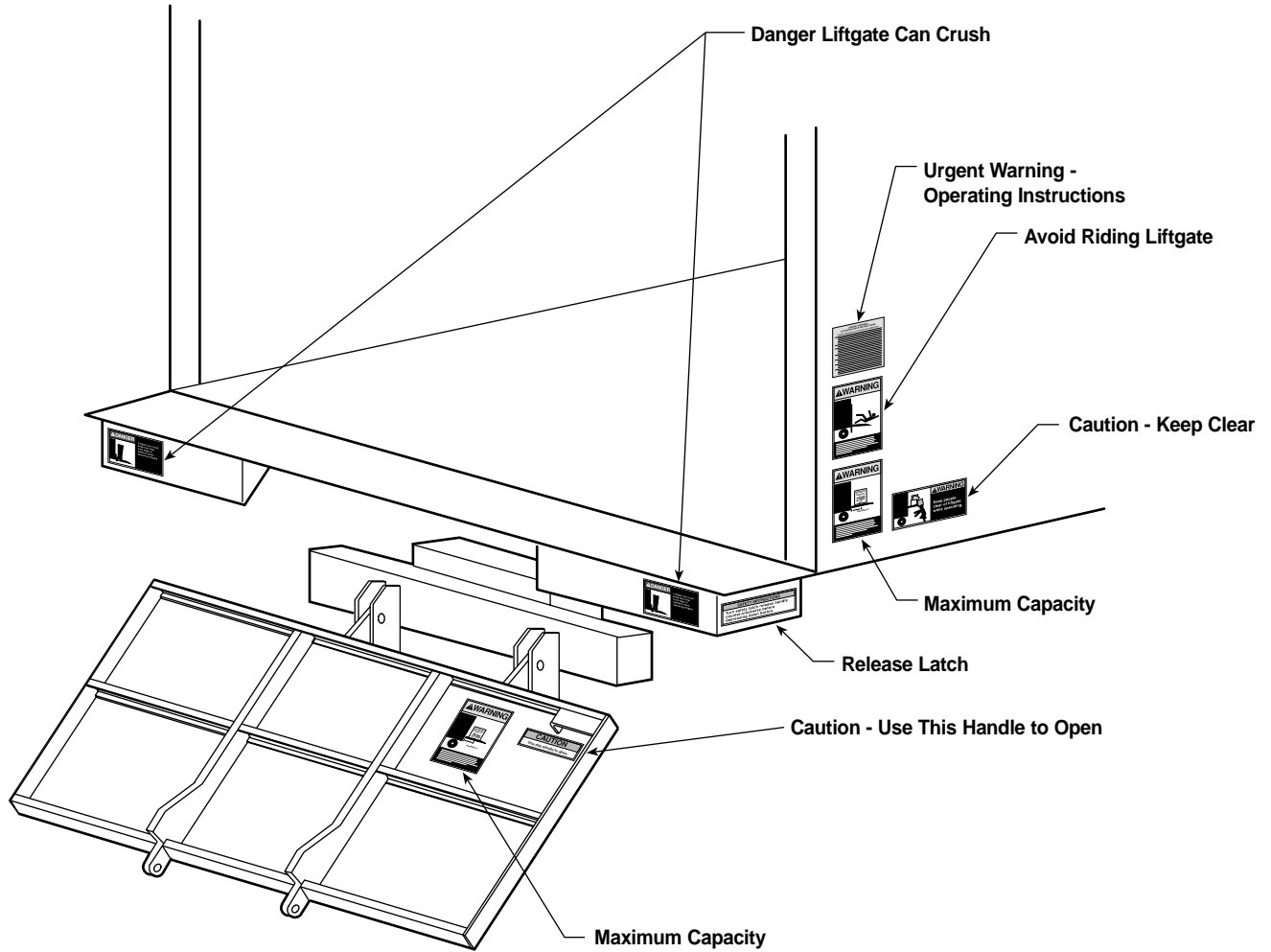

5.7 Operator's Manual

STEP 1 Write the model number and serial number of the liftgate in the Operator's Manual.

STEP 2 Ensure that the Operator's Manual is in the glove box of the truck.

5.8 Final Test

STEP 1 Load the liftgate as shown in the **Load Lifting Capabilities Table** below, with load centered on the platform.

Load Lifting Capabilities Table

DA Model	Test Load (full rated capacity)
DA25	2500 lbs.
DA30	3000 lbs.

STEP 2 Test the loaded liftgate following **Procedure 4.0: Test the Liftgate Operation**. Make sure you check the items shown in **Load-Testing Table** below.

Load-Testing Table

WHAT TO CHECK	POSSIBLE PROBLEMS	SOLUTIONS
Fasteners <ul style="list-style-type: none"> • Nuts • Bolts • Clevis pins • Cotter pins • Roller pins 	Loose Fasteners Parts missing Parts damaged	Tighten Fasteners Call Customer Service for OEM parts. USA: 800-289-1335 Canada: 416-421-7987
Welds	Cracked or broken welds	Call Customer Service. USA: 800-289-1335 Canada: 416-421-7987
Hydraulic Leaks	Tanks overfilled Loose fitting or loose hydraulic line	Make sure the tank is not overfilled Tighten loose fitting or hydraulic line
Platform is level with the floor of the truck when raised completely	Platform is not level.	Level platform using adjusting bolts.
Any unusual noise	Various	Call Customer Service. USA: 800-289-1335 Canada: 416-421-7987

5.9 Inspect Your Installation and Document Your Inspection



WARNING

Severe personal injury could result if you fail to check each of the following items.
DO NOT USE the liftgate if any of the following points are not checked.

Call Customer Service if you have any questions.

USA: 800-289-1335

Canada: 416-421-7987

NOTE Installation is not complete if you have not checked and verified the items listed on the Inspection Sheet .

Note! Warranty is void if Inspection Sheet is not complete.

STEP 1 Complete the **Inspection Sheet** on Page 33.

STEP 2 Keep the completed **Inspection Sheet** on file at the facility where the installation is performed.

Inspection Sheet

- ___ 1. Locking angle has been removed from cylinder.
- ___ 2. Pump reservoir is full to proper level when platform is fully lowered.
(Automatic transmission fluid is recommended).
- ___ 3. All tack welds are now complete welds.
- ___ 4. Platform meets Floor extension.
- ___ 5. Hook engages and disengages bail properly.
- ___ 6. Hydraulic components do not leak.
- ___ 7. Hydraulic components checked for leakage.
- ___ 8. Battery cable attached and clamped tight, but not pinched
- ___ 9. Lights wired properly and operational.
- ___ 10. License plate properly installed.
- ___ 11. All decals in place and legible.
- ___ 12. Opening arm working properly.
- ___ 13. Battery and liftgate grounded to chassis.
- ___ 14. Platform opens properly.
- ___ 15. Platform cycles completely up and down smoothly and freely, without hesitation.
- ___ 16. Platform folds smoothly and tucks under and latches properly in the in-transit position.
- ___ 17. Control switch and cable secured properly.
- ___ 18. Circuit Breaker installed.
- ___ 19. Master Disconnect Switch installed and operational..
- ___ 20. The liftgate's serial number and model number are written on the inside of the front cover of the Operator's Manual, in the space provided.
- ___ 21. Operator's Manual Kit is in the truck's glove box.
- ___ 22. Supervisor has demonstrated the Operating Instructions to the customer/driver.

Inspection Information:

Completed by: _____
(signature)

Name (please print): _____

Title: _____

Date: _____