



# DV Series™

Direct Vertical Lift Series  
Rail Style Liftgate

4500 lb. to 6600 lb. Capacity

## SERVICE PARTS LOCATOR

For Models: DV45 • DV55 • DV66



**Ultron Lift Inc.**  
**Les Hayons Ultron Inc.**  
12 Industrial St.  
Toronto, ON M4G 1Y9 Canada  
Phone: 416-421-7987  
Fax: 416-421-7927

**Ultron Lift Corp.**  
190 Lewis St. • PO Box 6126  
Buffalo, NY 14240-6126 USA  
Phone: 800-289-1335  
716-853-7994  
Fax: 716-854-5424

[www.ultronlift.com](http://www.ultronlift.com)

1/25/2008

## Introduction

Each Ultron liftgate is manufactured to stringent quality standards for years of reliable service. To ensure maximum performance of your Ultron liftgate, always specify and use “OEM Parts” from Ultron Lift.\* Look for Ultron Lift “OEM Parts” display rack at your local distributor or call us.

This manual is a complete parts listing for DV Liftgates from 4500 to 6000 lb. capacity. We have provided charts and diagrams to make the selection of the correct part as easy as possible.

This manual does not provide procedures for the servicing and repair of an Ultron liftgate. Service and repair should only be performed by an authorized Ultron Lift distributor. For information on the nearest authorized Ultron Lift distributor contact:



**Ultron Lift Inc.**  
**Les Hayons Ultron Inc.**  
12 Industrial St.  
Toronto, ON M4G 1Y9 Canada  
Phone: 416-421-7987  
Fax: 416-421-7927

**Ultron Lift Corp.**  
190 Lewis St. • PO Box 6126  
Buffalo, NY 14240-6126 USA  
Phone: 800-289-1335  
716-853-7994  
Fax: 716-854-5424

[www.ultronlift.com](http://www.ultronlift.com)

*\* The use of non-standard or makeshift parts can be extremely hazardous and result in serious injury or death.*

**Table of Contents**

Introduction.....2

Table of Contents .....3

General Information.....4

Ordering Information.....5

Key Components .....6

H-Frame (*Lifts Built before 9/08/2005*) .....7

H-Frame .....8

Platform – DV45 .....9

Platform – DV55 and DV66 .....10

Platform – Aluminum .....11

Platform – Roll Stop Option (Option 501) .....12

Electrical Components (*Lifts Built before 9/08/2005*).....13

Electrical Components.....14

Slider Assembly (*Lifts Built before 9/08/2005*).....15

Slider Assembly .....16

Cylinders, Hoses & Fittings.....17

Wear Pad Assembly .....18

Hydraulic Power Unit Assembly – Single Motor.....19

Hydraulic Power Unit Assembly – Dual Motor (*Lifts Built before 3/30/2006*) .....20

Hydraulic Power Unit Assembly – Dual Motor .....21

Decals.....22

Help and Service .....23

## General Information

### MODEL NUMBER CODING

The code and model numbers of a liftgate are references to its size, type and capacity. Using these numbers when ordering or specifying improves customer satisfaction and delivery.

Model Number: **DV4572**

<u>DV</u>	<u>45</u>	<u>72</u>
1	2	3

1. **LIFTGATE TYPE**

**DV** = Direct Lift Style Liftgate

2. **WEIGHT CAPACITY**

**45** = 4500 lb. Capacity

**55** = 5500 lb. Capacity

**66** = 6600 lb. Capacity

3. **DEPTH OF PLATFORM** (not including ramp)

**60** = 60" of platform loading area

**72** = 72" of platform loading area

**84** = 84" of platform loading area

**Ordering Information**

**STEP 1** Determine the assembly on which the desired part is located using either the Table of Contents (page 2) or the Key Components diagram (page 5)

**STEP 2** Identify the Item number from the appropriate part in the assembly diagram.

**STEP 3** Locate the appropriate row listing the Item number in the table below the assembly diagram.

ITEM #	DESCRIPTION	DV45	DV55 DV66
1	SLIDER, LH	68004	
2	WEAR PAD, UPPER BACK	68009	
3	WEAR PAD PLATE, UPPER FRONT	68014	

**STEP 4** Locate the column in the table that matches your model liftgate.

ITEM #	DESCRIPTION	DV45	DV55 DV66
1	SLIDER, LH	68004	
2	WEAR PAD, UPPER BACK	68009	
3	WEAR PAD PLATE, UPPER FRONT	68014	

**STEP 6** Find the correct part number.

ITEM #	DESCRIPTION	DV45	DV55 DV66
1	SLIDER, LH	68004	
2	WEAR PAD, UPPER BACK	68009	
3	WEAR PAD PLATE, UPPER FRONT	68014	

**STEP 7** Order the part

Model Number: DV4572  
 Part Name: Slider, LH  
 Quantity Required: 1  
 Part Number: 68004

# Key Components

Wear Pads:  
Pages 18

Power Unit:  
Single - Page 19  
Dual - Page 20

Decals:  
Page 21

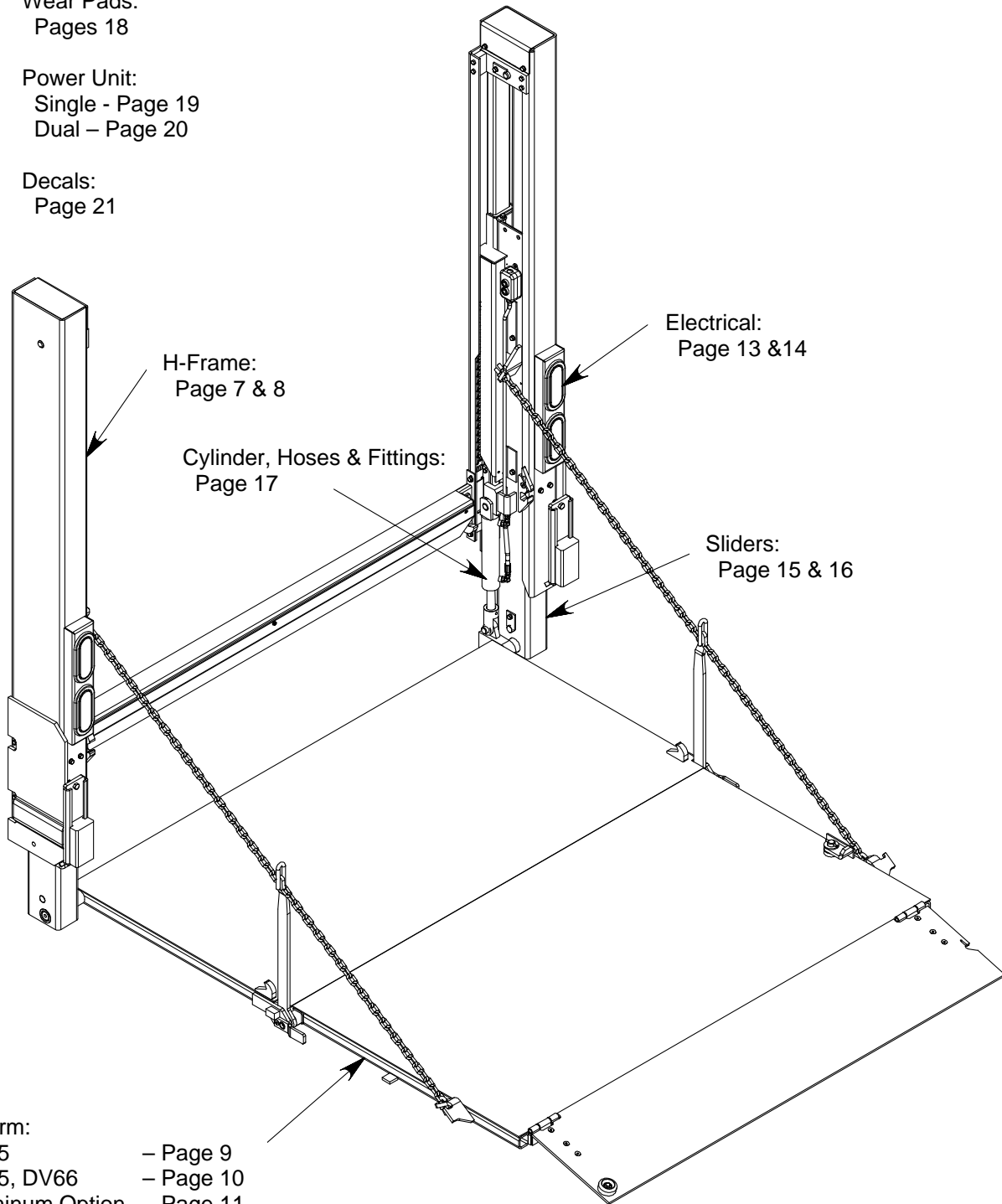

H-Frame:  
Page 7 & 8

Cylinder, Hoses & Fittings:  
Page 17

Electrical:  
Page 13 & 14

Sliders:  
Page 15 & 16

Platform:  
DV45 - Page 9  
DV55, DV66 - Page 10  
Aluminum Option - Page 11  
Roll Stop Option - Page 12

**H-Frame (Lifts Built before 9/08/2005)**

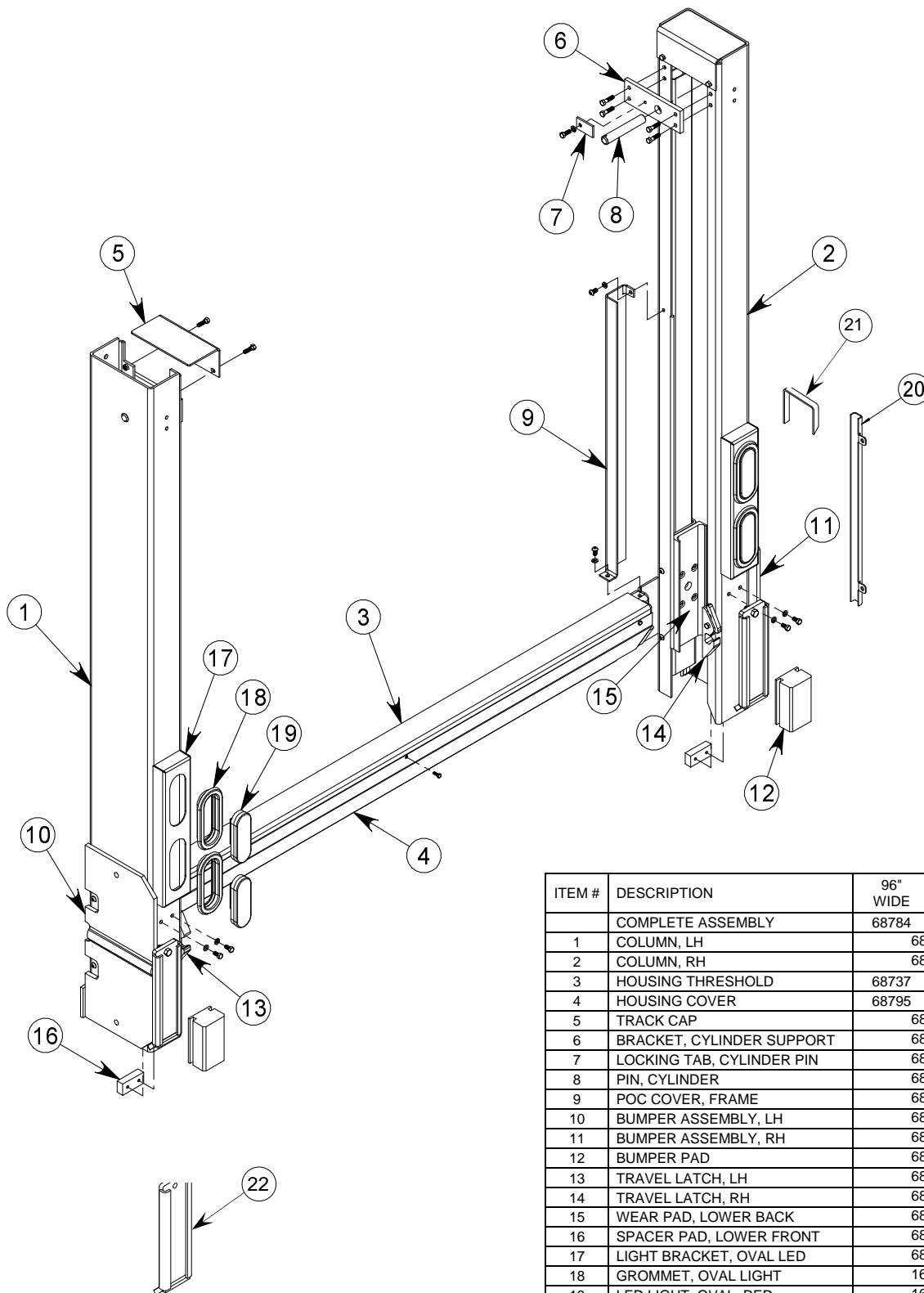

ITEM #	DESCRIPTION	96" WIDE	102" WIDE	QTY
	COMPLETE ASSEMBLY	68784	68840	1
1	COLUMN, LH	68701		1
2	COLUMN, RH	68702		1
3	HOUSING THRESHOLD	68737	68833	1
4	HOUSING COVER	68795	68340	1
5	TRACK CAP	68542		2
6	BRACKET, CYLINDER SUPPORT	68003		2
7	LOCKING TAB, CYLINDER PIN	68018		2
8	PIN, CYLINDER	68017		2
9	POC COVER, FRAME	68762		1
10	BUMPER ASSEMBLY, LH	68387		1
11	BUMPER ASSEMBLY, RH	68388		1
12	BUMPER PAD	68588		2
13	TRAVEL LATCH, LH	68788		1
14	TRAVEL LATCH, RH	68785		1
15	WEAR PAD, LOWER BACK	68007		2
16	SPACER PAD, LOWER FRONT	68026		2
17	LIGHT BRACKET, OVAL LED	68164		2
18	GROMMET, OVAL LIGHT	16137		4
19	LED LIGHT, OVAL, RED	16416		4
20	SWITCH WIRE COVER	68892		1
21	SWITCH GUARD	68893		1
22	BUMPER SLIDE CHANNEL	68384		2

H-Frame

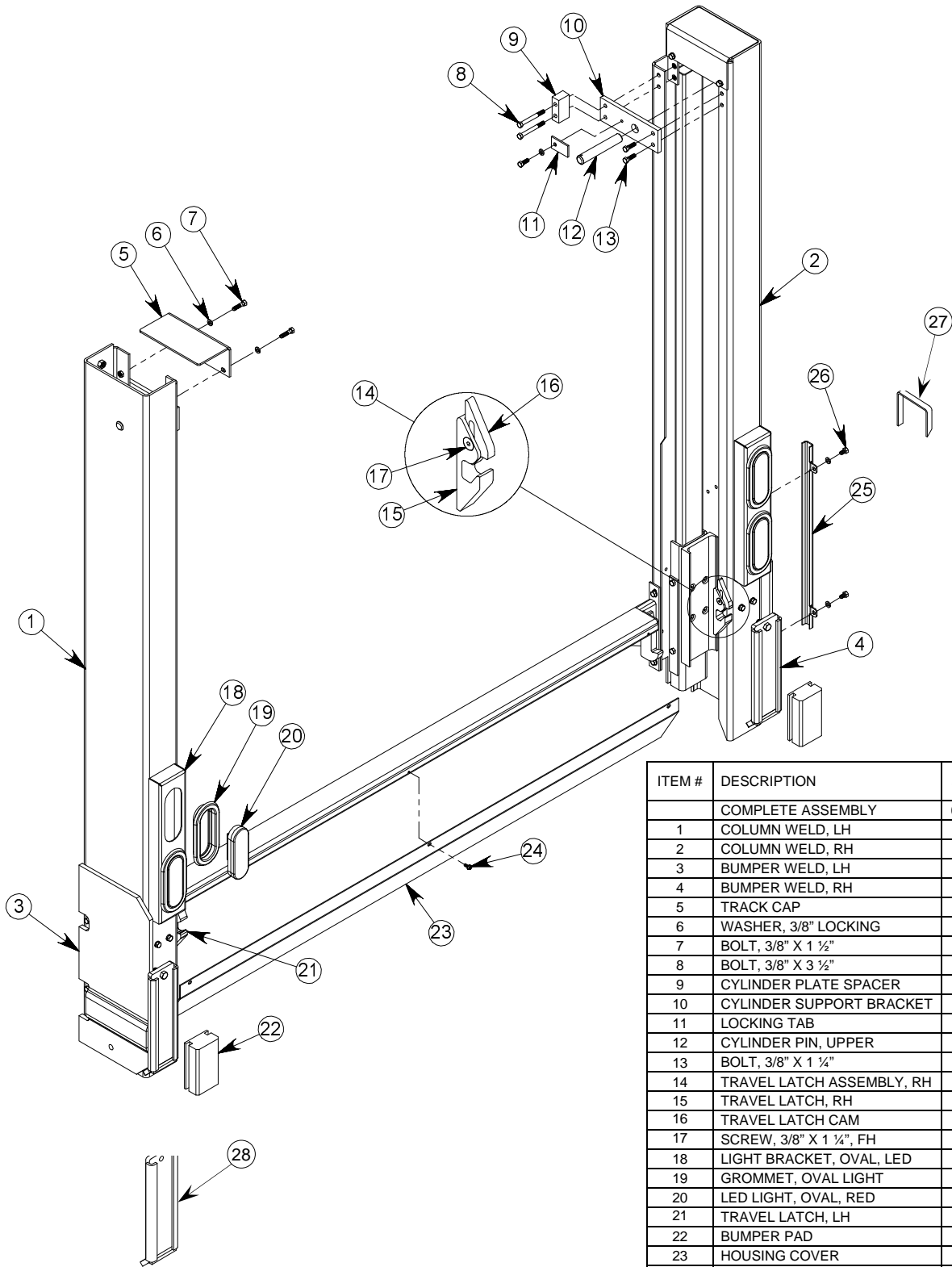

ITEM #	DESCRIPTION	96" WIDE	102" WIDE	QTY
	COMPLETE ASSEMBLY	68784	68840	1
1	COLUMN WELD, LH	68546		1
2	COLUMN WELD, RH	69007		1
3	BUMPER WELD, LH	68387		1
4	BUMPER WELD, RH	68388		1
5	TRACK CAP	68542		2
6	WASHER, 3/8" LOCKING	10092		8
7	BOLT, 3/8" X 1 1/2"	20209		4
8	BOLT, 3/8" X 3 1/2"	30287		2
9	CYLINDER PLATE SPACER	68971		1
10	CYLINDER SUPPORT BRACKET	68003		2
11	LOCKING TAB	68018		2
12	CYLINDER PIN, UPPER	68017		2
13	BOLT, 3/8" X 1 1/4"	10085		6
14	TRAVEL LATCH ASSEMBLY, RH	68787		1
15	TRAVEL LATCH, RH	68785		1
16	TRAVEL LATCH CAM	68786		1
17	SCREW, 3/8" X 1 1/4", FH	40096		1
18	LIGHT BRACKET, OVAL, LED	68164		2
19	GROMMET, OVAL LIGHT	16137		4
20	LED LIGHT, OVAL, RED	16416		4
21	TRAVEL LATCH, LH	68788		1
22	BUMPER PAD	68588		2
23	HOUSING COVER	68795	68340	1
24	SCREW, 1/4" X 5/8", TAPPING	10255		3
25	SWITCH WIRE COVER	68892		1
26	BOLT, 3/8" X 5/8"	10520		2
27	SWITCH GUARD	68893		1
28	BUMPER SLIDE CHANNEL	68384		2

**Platform – DV45**

Platforms are available in many different sizes, material types, and special options. The chart below is given for general reference only.

When ordering replacement platform sections, please provide the following information:

Platform Size      Depth, Width, Thickness  
 Ramp Type        Fixed, Flip, Roll Stops

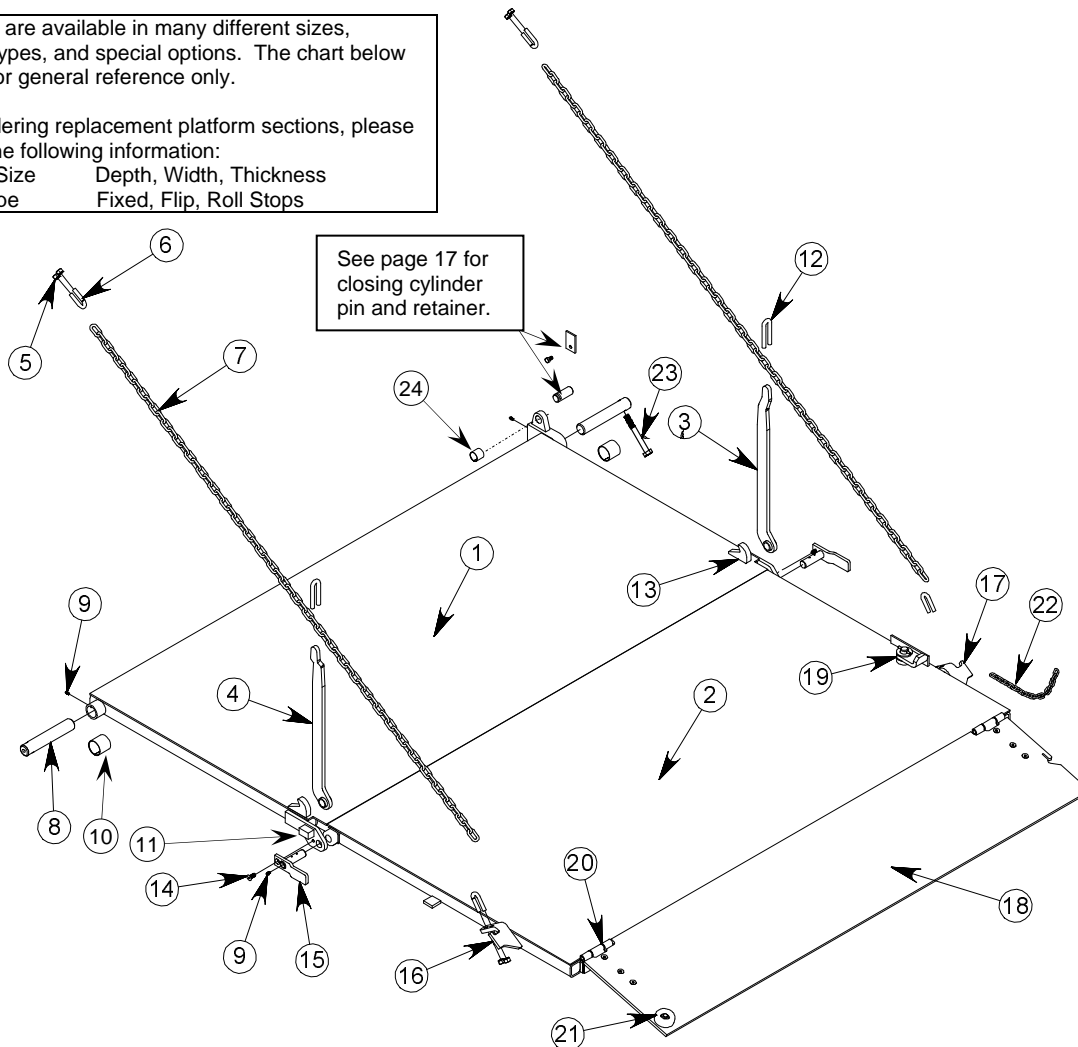

ITEM #	DESCRIPTION	DV45								QTY	
		80x60+12	80x72+16	80x72+12	80x84+16	86x60+12	86x72+16	86x72+12	86x84+16		
	PLATFORM ASSEMBLY	68441	68442	68443	68444	68445	68446	68447	68448	1	
1	PLATFORM WELD, MAIN	68855		68715		68857		68798		1	
2	PLATFORM WELD, RAMP	68856	68877	68818	68716	68858	68878	68806	68799	1	
3	SIDE ARM WELD, RH	68887		68792		68887		68792		1	
4	SIDE ARM WELD, LH	68888		68793		68888		68793		1	
5	NUT, 1/2"									30046	8
6	U-BOLT									30045	4
7	SIDE CHAIN	30218 – 67"		30218 – 80"		30218 – 67"		30218 – 80"		2	
8	PIN, SLIDER HINGE									68739	2
9	GREASE FITTING									68473	4
10	BUSHING, 1 1/2" ID x 1 1/2"									68119	2
11	PLATFORM STOP									68474	1
12	CHAIN HOLDER									68364	2
13	DOCK LOCK									68794	2
14	SCREW, 3/8" X 1, LOCKING									68961	2
15	PIN ASSY, FOLDING HINGE									68646	2
16	TRAVEL EAR, LH									68709	1
17	TRAVEL EAR, RH									68708	1
18	FLIP RAMP	-	68435	-	68435	-	68438	-	68438	0/1	
19	LATCH ASSY, FLIP RAMP	-	68427	-	68427	-	68427	-	68427	0/1	
20	HINGE, FLIP RAMP	-	40094	-	40094	-	40094	-	40094	0/2	
21	BUMPER, FLIP RAMP	-	16213	-	16213	-	16213	-	16213	0/1	
22	CHAIN, FLIP RAMP	-	30302	-	30302	-	30302	-	30302	1	
23	BOLT, 3/8 X 3									30284	2
24	BUSHING, 1" ID x 3/4"									25445	1

**Platform – DV55 and DV66**

Platforms are available in many different sizes, material types, and special options. The chart below is given for general reference only.

When ordering replacement platform sections, please provide the following information:

Platform Size      Depth, Width, Thickness  
 Ramp Type        Fixed, Flip, Roll Stops

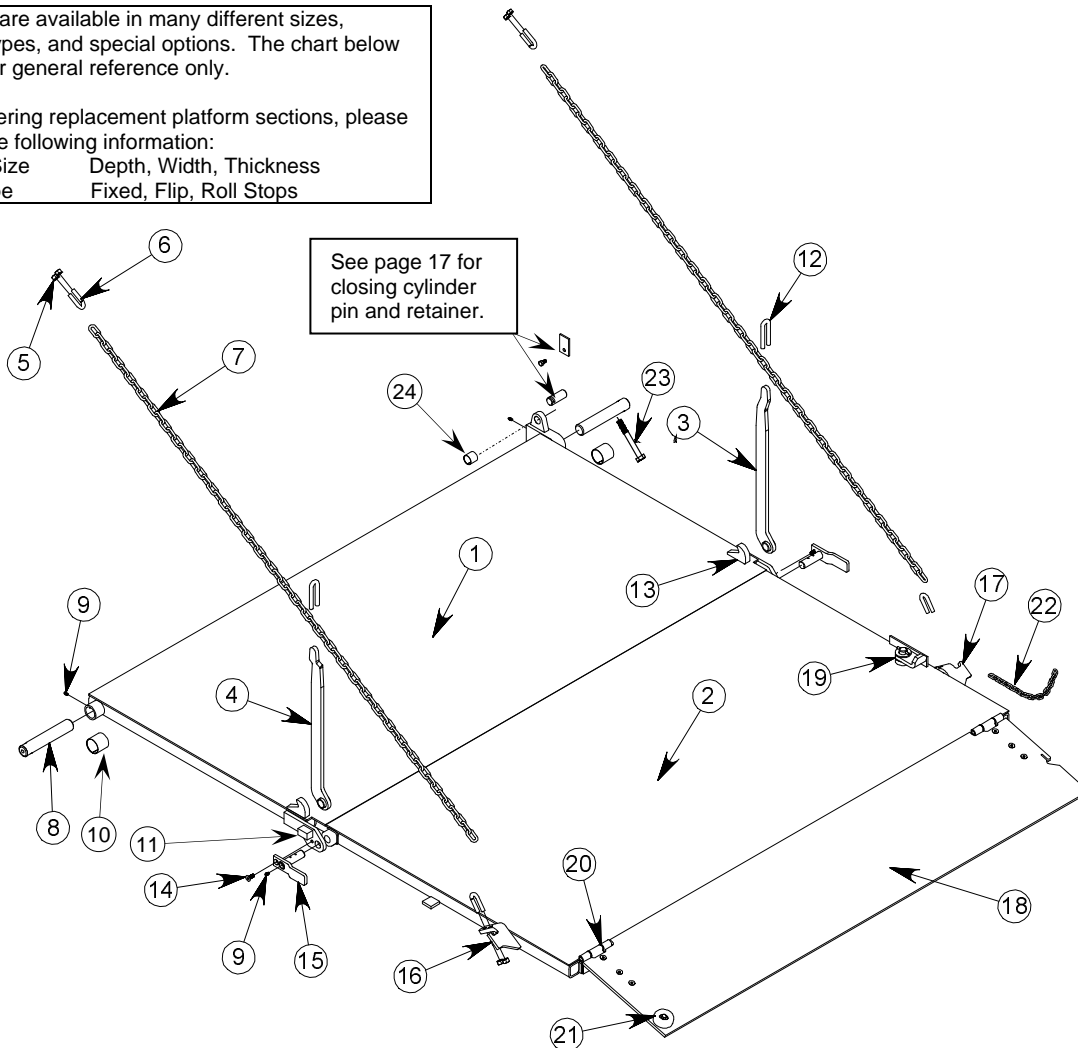

ITEM #	DESCRIPTION	DV55 and DV66								QTY	
		80x60+12	80x72+16	80x72+12	80x84+16	86x60+12	86x72+16	86x72+12	86x84+16		
	PLATFORM ASSEMBLY	68461	68462	68463	68464	68465	68466	68467	68468	1	
1	PLATFORM WELD, MAIN	68859		68830		68861		68831		1	
2	PLATFORM WELD, RAMP	68860	68879	68824	68826	68862	68880	68827	68829	1	
3	SIDE ARM WELD, RH	68887		68792		68887		68792		1	
4	SIDE ARM WELD, LH	68888		68793		68888		68793		1	
5	NUT, 1/2"									30046	8
6	U-BOLT									30045	4
7	SIDE CHAIN	68305 – 67"		68305 – 80"		68305 – 67"		68305 – 80"		2	
8	PIN, SLIDER HINGE									68739	2
9	GREASE FITTING									68473	4
10	BUSHING, 1 1/2" ID x 1 1/2"									68119	2
11	PLATFORM STOP									68474	1
12	CHAIN HOLDER									68364	2
13	DOCK LOCK									68794	2
14	SCREW, 3/8" X 1, LOCKING									68961	2
15	PIN ASSY, FOLDING HINGE									68646	2
16	TRAVEL EAR, LH									68709	1
17	TRAVEL EAR, RH									68708	1
18	FLIP RAMP	-	68435	-	68435	-	68438	-	68438	0/1	
19	LATCH ASSY, FLIP RAMP	-	68427	-	68427	-	68427	-	68427	0/1	
20	HINGE, FLIP RAMP	-	40094	-	40094	-	40094	-	40094	0/2	
21	BUMPER, FLIP RAMP	-	16213	-	16213	-	16213	-	16213	0/1	
22	CHAIN, FLIP RAMP	-	30302	-	30302	-	30302	-	30302	0/1	
23	BOLT, 3/8 X 3									30284	2
24	BUSHING, 1" ID x 3/4"									25445	1

## Platform – Aluminum

Platforms are available in many different sizes, material types, and special options. The chart below is given for general reference only.

When ordering replacement platform sections, please provide the following information:  
 Platform Size      Depth, Width, Thickness  
 Ramp Type          Fixed, Flip, Roll Stops

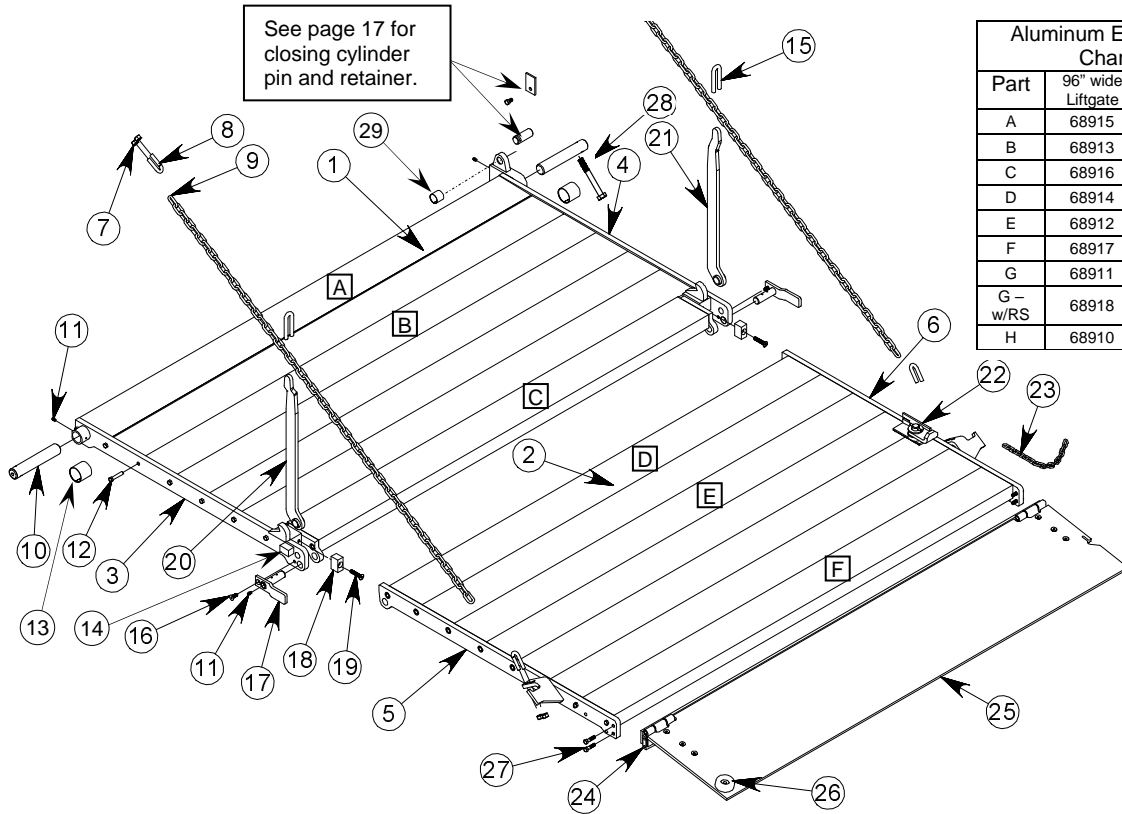

Part	96" wide Liftgate	102 wide Liftgate
A	68915	68905
B	68913	68903
C	68916	68906
D	68914	68919
E	68912	68902
F	68917	68907
G	68911	68901
G - w/RS	68918	68908
H	68910	68900

ITEM #	DESCRIPTION	Aluminum Platform								QTY
		80x60+12	80x72+16	80x72+12	80x84+16	86x60+12	86x72+16	86x72+12	86x84+16	
	PLATFORM ASSEMBLY	69061	69062	69063	69058	68691	69004	68950	68949	1
1	PLATFORM ASSEMBLY, MAIN	69064		69059		68692		68349		1
2	PLATFORM ASSEMBLY, RAMP	69065	69069	69071	69060	68693	69003	68367	68368	1
3	SIDEPLATE WELD, MAIN, LH	68695		68346		68695		68346		1
4	SIDEPLATE WELD, MIAN, RH	68694		68345		68694		68345		1
5	SIDEPLATE WELD, RAMP, LH	68698		68348		68698		68348		1
6	SIDEPLATE WELD, RAMP, RH	68697		68347		68697		68347		1
7	NUT, 1/2"	30046								8
8	U-BOLT	30045								4
9	SIDECHAIN	DV45 = 30218, DV55 & DV66 = 68305								13FT
10	PIN, SLIDER HINGE	68739								2
11	GREASE FITTING	68473								4
12	BOLT, 3/8, TAPTITE	68937								28
13	BUSHING, 1 1/2" ID x 1 1/2"	68119								2
14	PLATFORM STOP	68474								1
15	CHAIN HOLDER	68364								2
16	SCREW, 3/8 X 1, LOCKING	68961								2
17	PIN ASSY, FOLDING HINGE	68646								2
18	LEVELING SHIM	68934								2
19	SCREW, 3/8 X 2	68954								2
20	SIDEARM WELD, LH	68888								1
21	SIDEARM WELD, RH	68887								1
22	LATCH ASSY, FLIP RAMP, AL	-	69002	-	69002	-	69002	-	69002	1
23	CHAIN, FLIP RAMP	-	30302	-	30302	-	30302	-	30302	1
24	FLIP RAMP MOUNT	-	69066	-	69066	-	68366	-	68366	1
25	FLIP RAMP	-	68435	-	68435	-	68438	-	68438	1
26	BUMPER, FLIP RAMP	-	16213	-	16213	-	16213	-	16213	1
27	BOLT, 3/8 X 1 1/2	-	20209	-	20209	-	20209	-	20209	1
28	BOLT, 3/8 X 3	30284								2
29	BUSHING, 1" ID x 3/4"	25445								1

## Platform – Roll Stop Option (Option 501)

Platforms are available in many different sizes, material types, and special options. The chart below is given for general reference only.

When ordering replacement platform sections, please provide the following information:

Platform Size      Depth, Width, Thickness  
 Ramp Type        Fixed, Flip, Roll Stops

Part	96" wide Liftgate	102 wide Liftgate
D	68914	68919
E	68912	68902
F	68917	68907
G	68911	68901
G-w/RS	68918	68908
H	68910	68900

### ALUMINUM PLATFORM

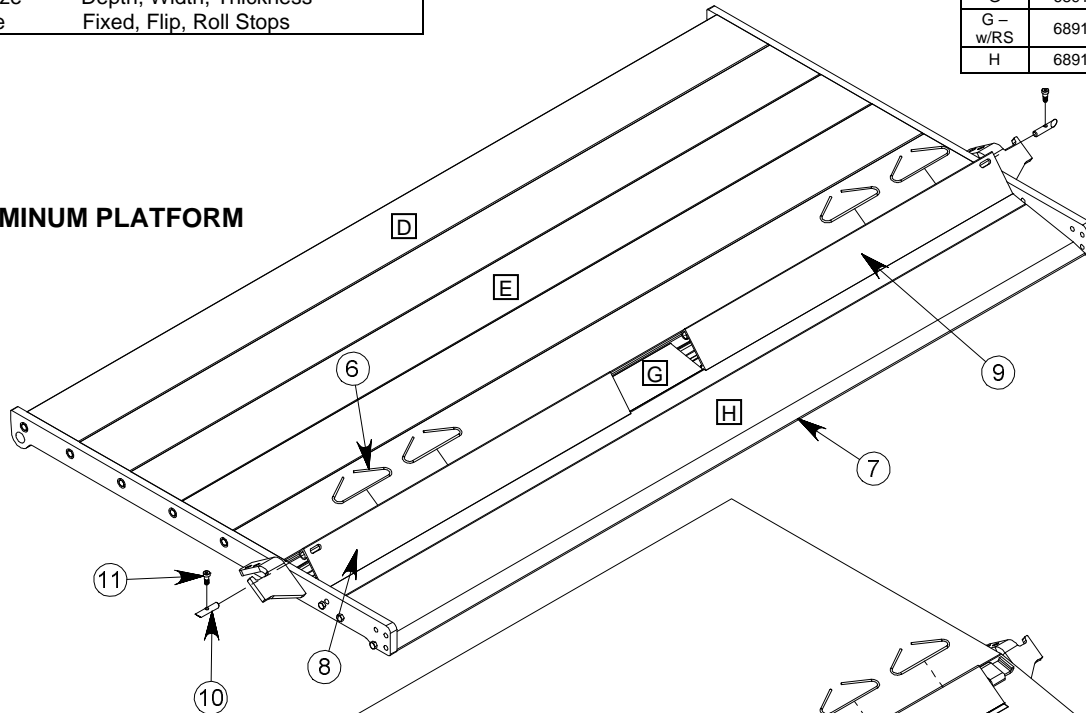

### STEEL PLATFORM

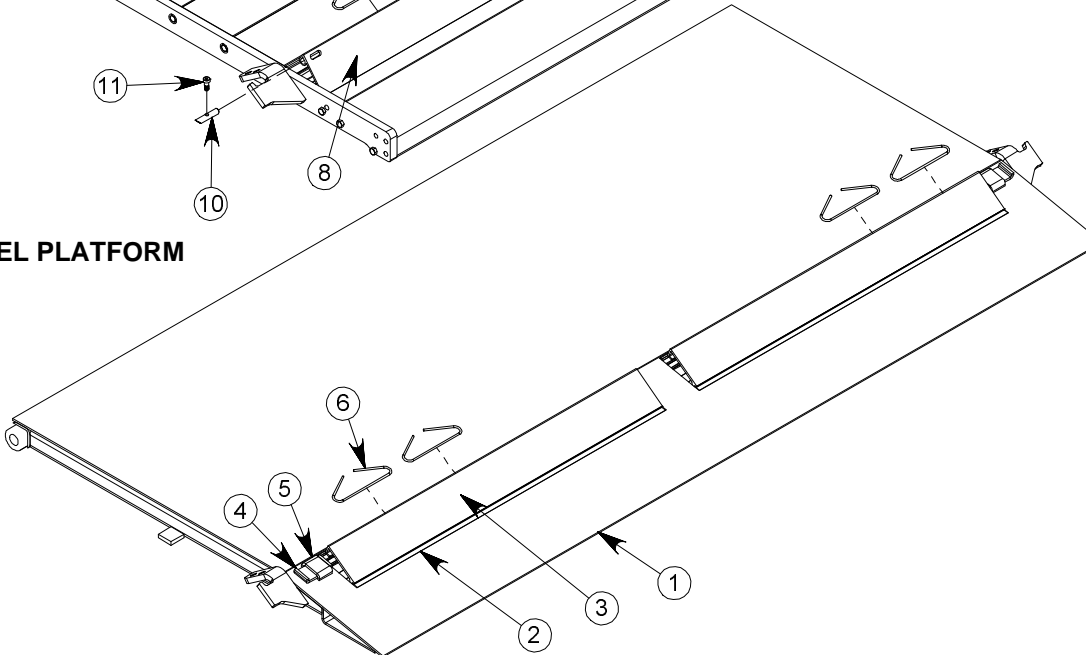

	ITEM #	DESCRIPTION	80x60+12		80x72+12		86x60+12		86x72+12		QTY
			DV45	DV55 DV66	DV45	DV55 DV66	DV45	DV55 DV66	DV45	DV55 DV66	
S T E E L	1	PLATFORM WELD, RAMP	68867	68869	68821	68825	68868	68870	68812	68828	1
	2	ROLL STOP EXT, BOTTOM					68920				2
	3	ROLL STOP EXT, TOP					68909				2
	4	ROLL STOP RETAINER, SLIDE					68396				2
	5	ROLL STOP RETAINER					68395				2
	6	ROLL STOP SPRING					68440				4
A L U M	7	PLATFORM ASSEMBLY, RAMP	69068		69071		69037		69015		1
	8	ROLL STOP EXT, TOP, LH					69011				1
	9	ROLL STOP EXT, TOP, RH					69012				1
	10	PIN, ROLL STOP					69014				2
	11	SHOULDER SCREW, RS					69013				2

**Electrical Components (Lifts Built before 9/08/2005)**

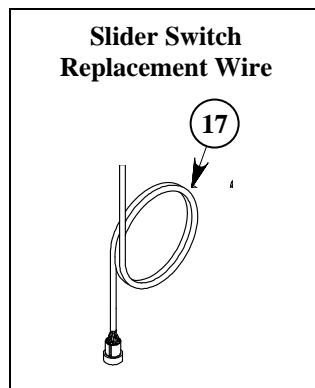
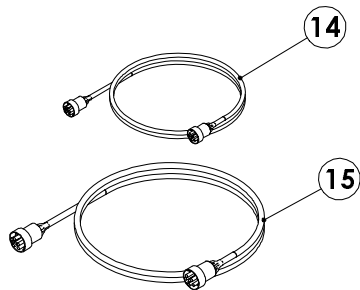
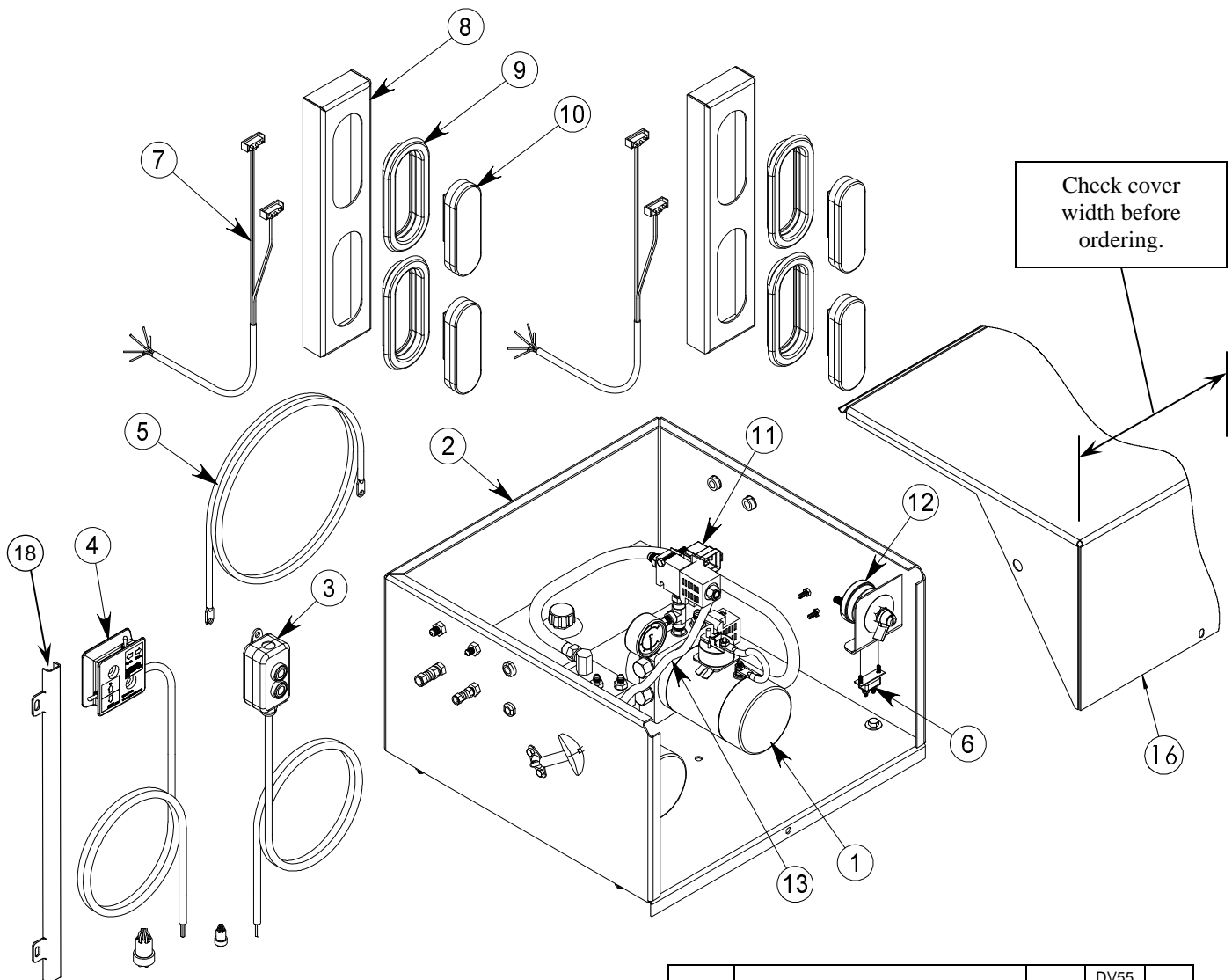

ITEM #	DESCRIPTION	DV45	DV55 DV66	QTY
		68030	68839	
1	POWER UNIT			1
2	POWER UNIT BOX		68676	1
3	SWITCH, SLIDER MOUNT		68337	1
4	SWITCH, MAIN		68891	1
5	BATTERY CABLE		68457	1
6	CIRCUIT BREAKER, 15 AMP		11062	1
7	HARNESS, TWO LIGHT		68231	2
8	BRACKET, TWO LIGHT, OVAL		68164	2
9	GROMMET, OVAL LIGHT		16137	4
10	LIGHT, STOP, LED		16416	4
11	RELAY		20870	1
12	MASTER DISCONNECT		20450	1
13	WIRE HARNESS		68335	1
-	DIODE IN HARNESS (NOT SHOWN)		16662	4
14	EXTENSION, 3 WIRE, 10FT		68942	1
14	EXTENSION, 3 WIRE, 20FT		68849	1
15	EXTENSION, 6 WIRE, 10FT		68941	1
15	EXTENSION, 6 WIRE, 20FT		68848	1
16	BOX COVER - 28" WIDE		68678	1
16	BOX COVER - 24" WIDE		69075	1
17	WIRE ASSY, SLIDER SWITCH		68689	1
18	SWITCH WIRE COVER		68892	1

**Electrical Components**

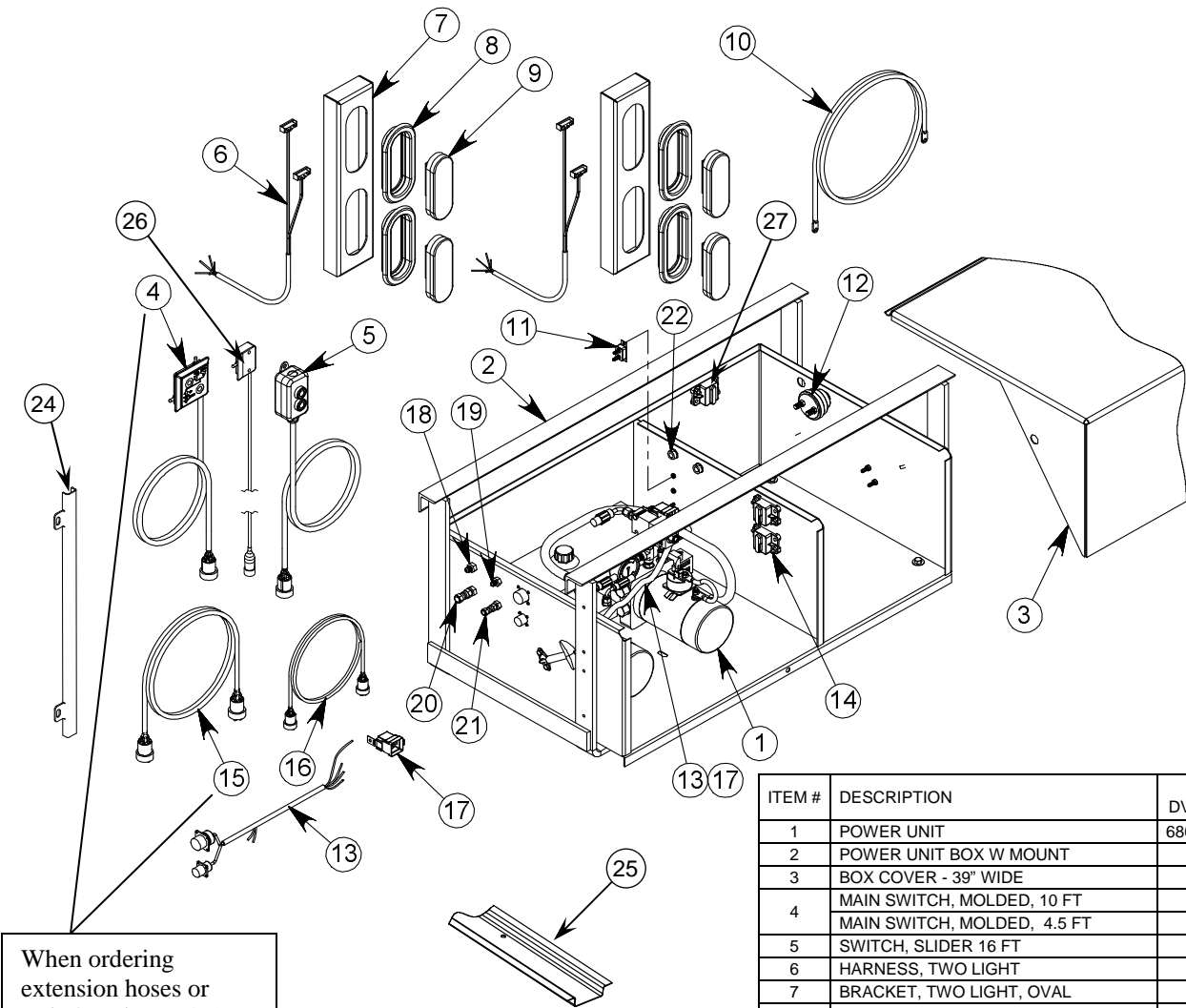

When ordering extension hoses or switches (items 4, 15, 16 & 26) choose the part number for the length that matches your existing part.

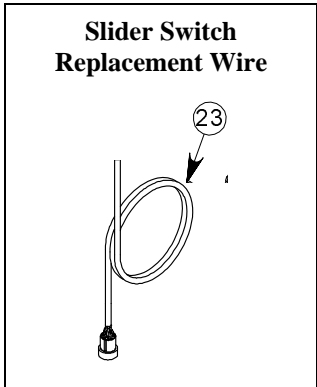

ITEM #	DESCRIPTION	DV45	DV55 DV66	QTY
1	POWER UNIT	68030	69088	1
2	POWER UNIT BOX W MOUNT		69034	1
3	BOX COVER - 39" WIDE		69045	1
4	MAIN SWITCH, MOLDED, 10 FT		68891	1
	MAIN SWITCH, MOLDED, 4.5 FT		69136	
5	SWITCH, SLIDER 16 FT		68337	1
6	HARNESS, TWO LIGHT		16093	2
7	BRACKET, TWO LIGHT, OVAL		68164	2
8	GROMMET, OVAL LIGHT		16137	4
9	LIGHT, STOP, LED		16449	4
10	BATTERY CABLE, 40 FT		68457	1
11	CIRCUIT BREAKER, 15 AMP		11062	1
12	DISCONNECT		20450	1
13	WIRING HARNESS		69078	1
-	DIODE IN HARNESS (NOT SHOWN)		16662	4
14	CIRCUIT BREAKER, 150 AMP		20831	1/2
15	EXTENSION, 6 WIRE, 10 FT		68941	1
	EXTENSION, 6 WIRE, 23 FT		68848	
	EXTENSION, 6 WIRE, 13 FT		69183	
	EXTENSION, 6 WIRE, 26 FT		69187	
16	EXTENSION, 3 WIRE, 10 FT		68942	1
	EXTENSION, 3 WIRE, 20 FT		68849	
	EXTENSION, 3 WIRE, 13 FT		69182	
	EXTENSION, 3 WIRE, 26 FT		69186	
17	RELAY		20870	1
18	BULKHEAD, 3/8"		68059	2
19	BULKHEAD, 1/4"		20532	2
20	FITTING, 3/8 JIC, SWIVEL		68073	1
21	FITTING, 1/4 JIC, SWIVEL		68072	1
22	STRAIN RELIEF, 7/8		16049	3
23	WIRE ASSY, SLIDER SWITCH		68689	1
24	SWITCH WIRE COVER		68892	1
25	HOSE & WIRE GUIDE 96" LONG		68380	1
	MOLDED SINGLE TOGGLE, 16 FT		16657	
	MOLDED SINGLE TOGGLE, 9.5 FT		69137	1
27	CIRCUIT BREAKER, 150A, AUTO RESET		20806	1

**Slider Assembly (Lifts Built before 9/08/2005)**

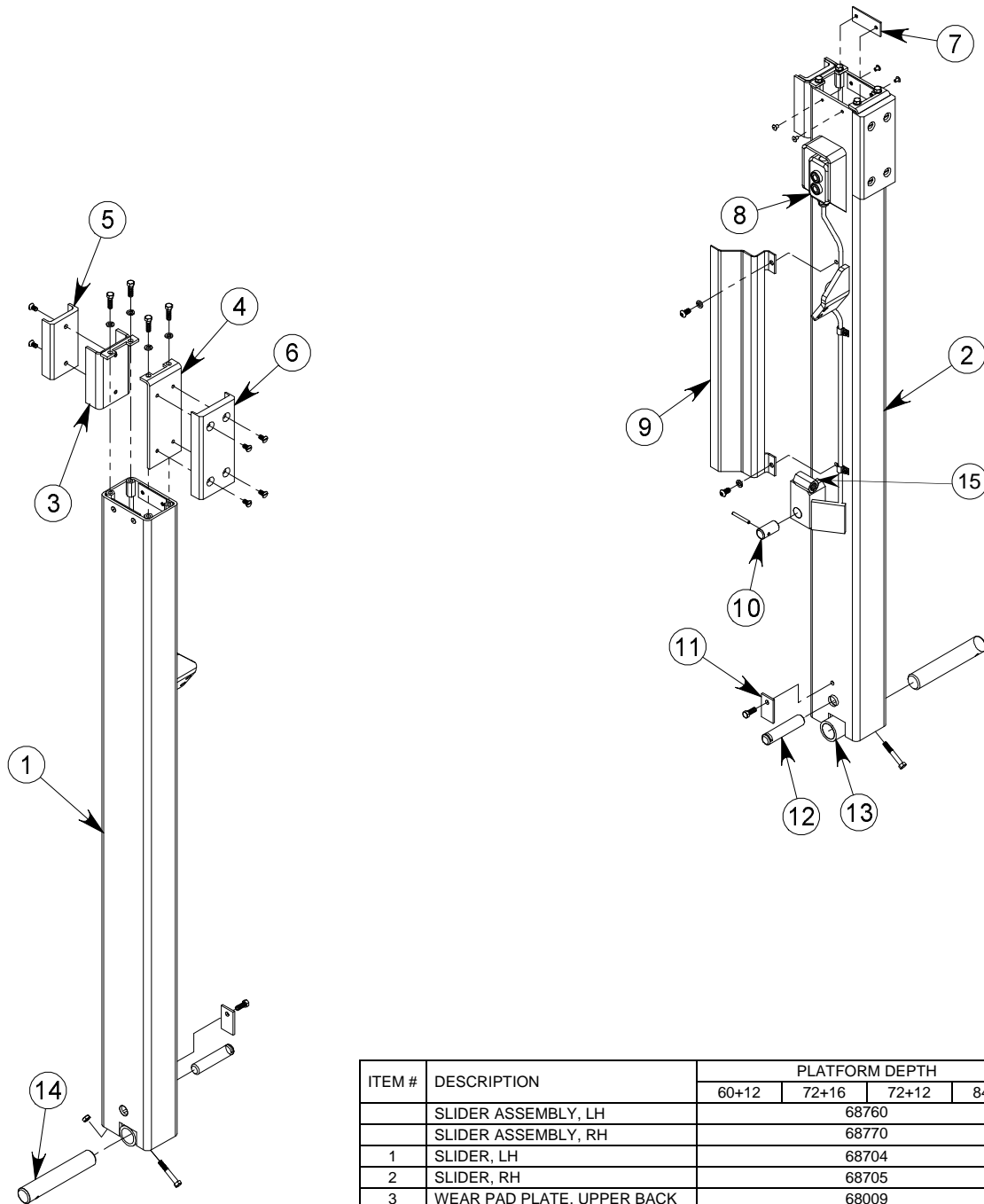

ITEM #	DESCRIPTION	PLATFORM DEPTH			QTY
		60+12	72+16	72+12	
	SLIDER ASSEMBLY, LH		68760		1
	SLIDER ASSEMBLY, RH		68770		1
1	SLIDER, LH		68704		1
2	SLIDER, RH		68705		1
3	WEAR PAD PLATE, UPPER BACK		68009		2
4	WEAR PAD PLATE, UPPER FRONT		68014		2
5	WEAR PAD, UPPER BACK		68011		2
6	WEAR PAD, UPPER FRONT		68024		2
7	WEAR PAD, CYLINDER		68048		4
8	SWITCH, SLIDER MOUNT		68337		1
9	HOSE GUARD		68533		1
10	PIN, POC, UPPER		68529		1
11	LOCKING TAB, CYLINDER PIN		68018		2
12	PIN, CYLINDER, LOWER		68033		2
13	HINGE TUBE		68623		2
14	HINGE PIN		68739		2
15	PLATFORM CLOSING STOP		68474		2

# Slider Assembly

Verify the type of switch you have before ordering.

- Item 9 – Push button switch
- Item 10 – Toggle switch

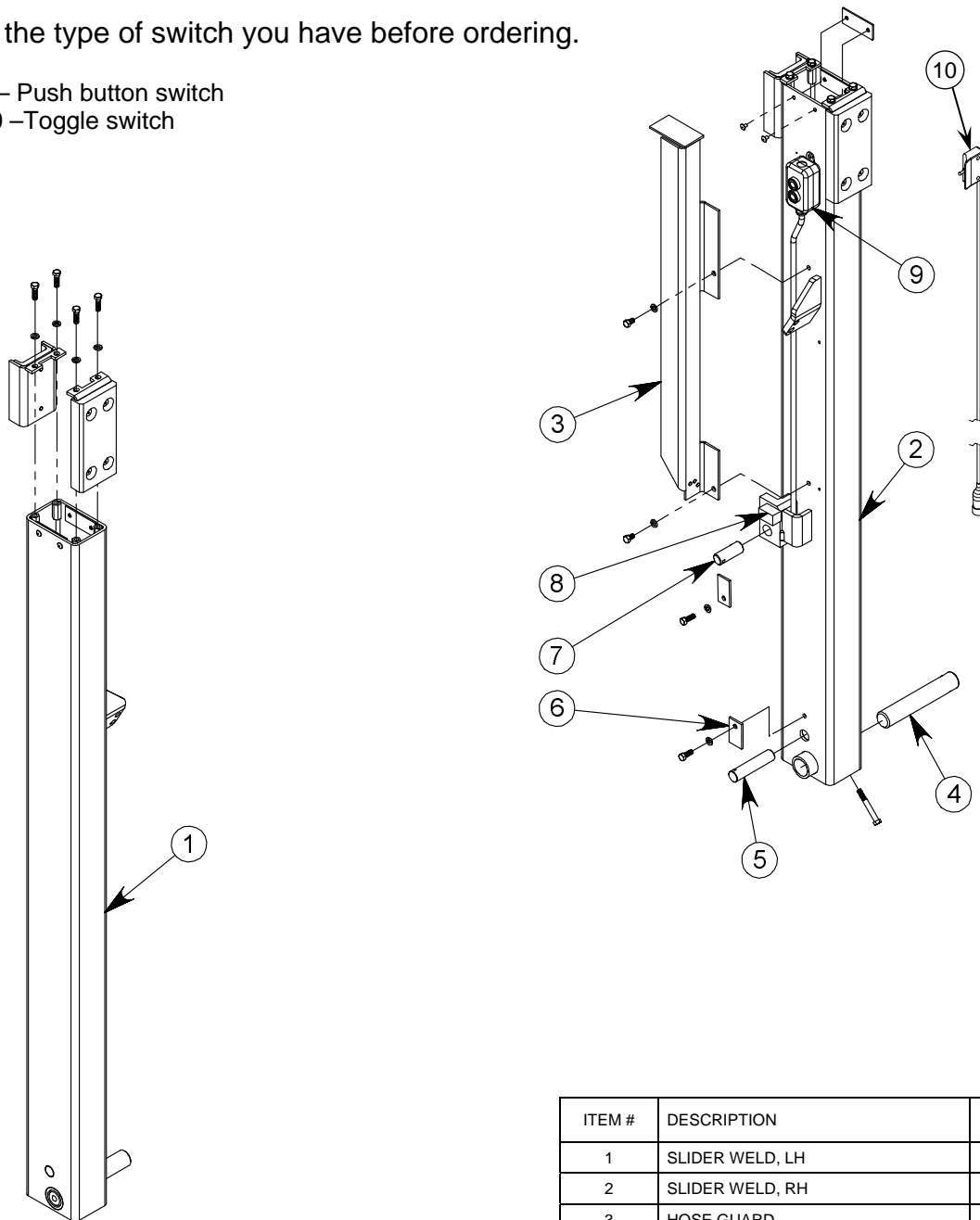

ITEM #	DESCRIPTION	Part #	QTY
1	SLIDER WELD, LH	68543	1
2	SLIDER WELD, RH	68544	1
3	HOSE GUARD	69000	1
4	PIN, SLIDER HINGE	68739	2
5	PIN, CYLINDER, LOWER	68033	2
6	LOCKING TAB	68018	3
7	PIN, 1 x 2 3/8, SLOTTED	69091	1
8	PLATFORM CLOSING STOP	68474	1
9	SWITCH, 2 BUTTON	68337	1
10	MOLDED SINGLE TOGGLE, 16 FT	16557	1
	MOLDED SINGLE TOGGLE, 9.5 FT	69137	

Cylinders, Hoses & Fittings

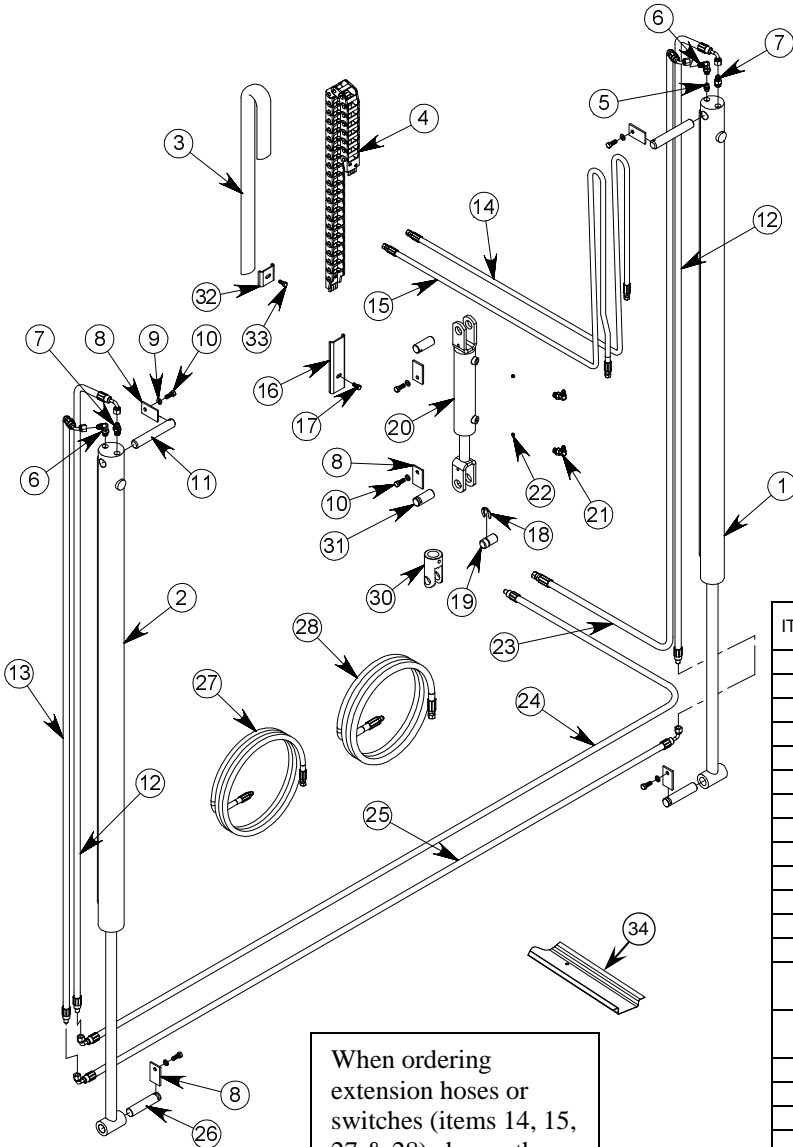

**Sleeve Replacement Kit**  
Hoses and switch wire are pre-assembled in sleeve.

**E-chain Replacement Kit**  
Hoses and switch wire are pre-assembled in e-chain.

When ordering extension hoses or switches (items 14, 15, 27 & 28) choose the part number for the length that matches your existing part.

ITEM #	DESCRIPTION	DV45	DV55 DV66	QTY
1	LIFT CYLINDER, RH	68022	68025	1
2	LIFT CYLINDER, LH	68025	68027	1
3	SLEEVE, PROTECTION		69046	1
4	HOSE GUIDE, E-CHAIN		68475	1
5	VALVE, PRESSURE COMP		68490	1
6	FITTING, 90, 9/16 ORB X 3/8 JICM		68363	2
7	FITTING, 9/16 ORB X 3/8 JICM		68057	2
8	LOCKING TAB		68018	6
9	WASHER, 3/8" LOCKING		10092	4
10	BOLT, 3/8 X 3/4		30027	6
11	PIN, CYLINDER, UPPER		68017	2
12	HOSE, HP, 3/8 X 88.5"		68391	2
13	HOSE, HP, 3/8 X 86.5"		68379	1
14	HOSE, HP, 3/16 X 120"		68398	1
	HOSE, HP, 3/16 X 90"		69135	
15	HOSE, HP, 3/16 X 128"		68399	1
	HOSE, HP, 3/16 X 98"		69134	
16	HOSE RETAINING BRACKET		68763	1
17	BOLT, 5/16 X 1		10075	1
18	RETAINING RING		68962	2
19	PIN, OPEN/CLOSE CYLINDER		68529	2
20	CYLINDER, OPEN/CLOSE		68738	1
21	FITTING, 90, 9/16 X 1/4 JICM, TAP		68362	2
22	FLOW RESTRICTOR ORIFICE		68312	2
23	HOSE, HP, 3/8 X 160", FEMALE		68067	1
	HOSE, HP, 3/8 X 122", FEMALE		69132	
24	HOSE, HP, 3/8 X 160", MALE		68068	1
	HOSE, HP, 3/8 X 118", MALE		69133	
25	HOSE, HP, 3/8 X 108"		68390	1
26	PIN, CYLINDER, LOWER		68033	2
27	HOSE, HP, 1/4 X 10 FT		68944	2
	HOSE, HP, 1/4 X 23 FT		68196	
	HOSE, HP, 1/4 X 13 FT		69180	
	HOSE, HP, 1/4 X 26 FT		69184	
28	HOSE, HP, 3/8 X 10 FT		68943	2
	HOSE, HP, 3/8 X 23 FT		68195	
	HOSE, HP, 3/8 X 13 FT		69181	
	HOSE, HP, 3/8 X 26 FT		69185	
29	E-CHAIN ASSEMBLY		68978	1
30	CLEVIS ONLY, SCREW ON,		68852	1
31	PIN, 1 x 2 3/8, SLOTTED		69091	2
32	HOSE RETAINING BRACKET, 2"		68417	2
33	BOLT, 5/16 x 1 1/2		16195	2
34	HOSE & WIRE GUIDE 96" LONG		68380	1
35	SLEEVE, HOSE, SWITCH&		69130	1

CYLINDER CHART

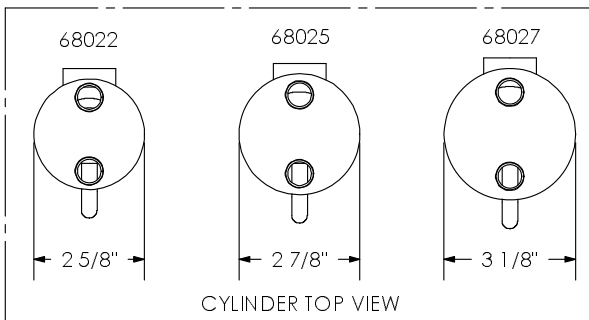

**Wear Pad Assembly**

**SLIDER, UPPER, BACK**

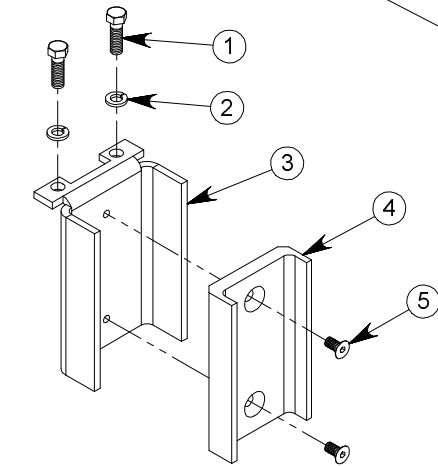

**SLIDER, CYLINDER PAD**

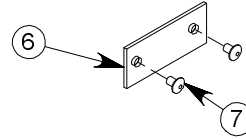

**SLIDER, UPPER, FRONT**

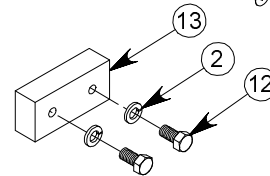
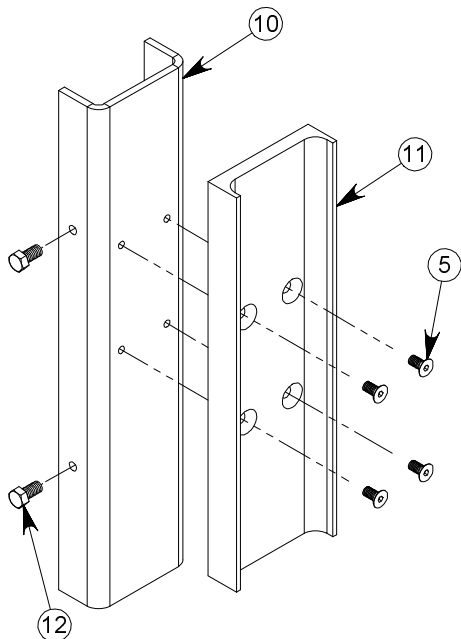
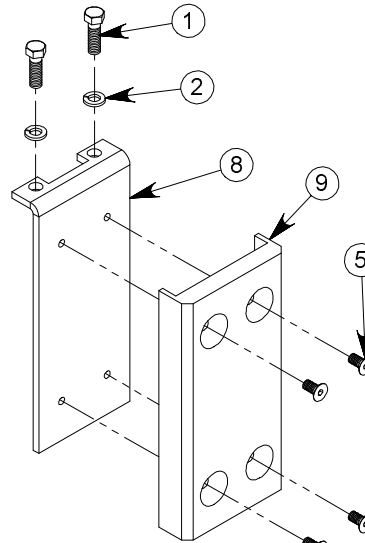

**COLUMN, LOWER, FRONT**

**COLUMN, LOWER, BACK**

ITEM #	DESCRIPTION	Part #	QTY
1	BOLT, 3/8 X 1 1/4	10085	8
2	WASHER, 3/8 LOCKING	10092	8
3	WEAR PAD PLATE, UPPER BACK	68009	2
4	WEAR PAD, UPPER BACK	68011	2
5	SCREW, 5/16 FLAT HEAD LOCKING	68850	20
6	WEAR PAD, CYLINDER	68048	4
7	RIVET, 1/4	40198	8
8	WEAR PAD PLATE, UPPER FRONT	68014	2
9	WEAR PAD, UPPER FRONT	68024	2
10	WEAR PAD PLATE, LOWER BACK	68006	2
11	WEAR PAD, LOWER BACK	68007	2
12	BOLT, 3/8 X 3/4	30027	12
13	WEAR PAD, LOWER FRONT	68026	2

**Hydraulic Power Unit Assembly – Single Motor**

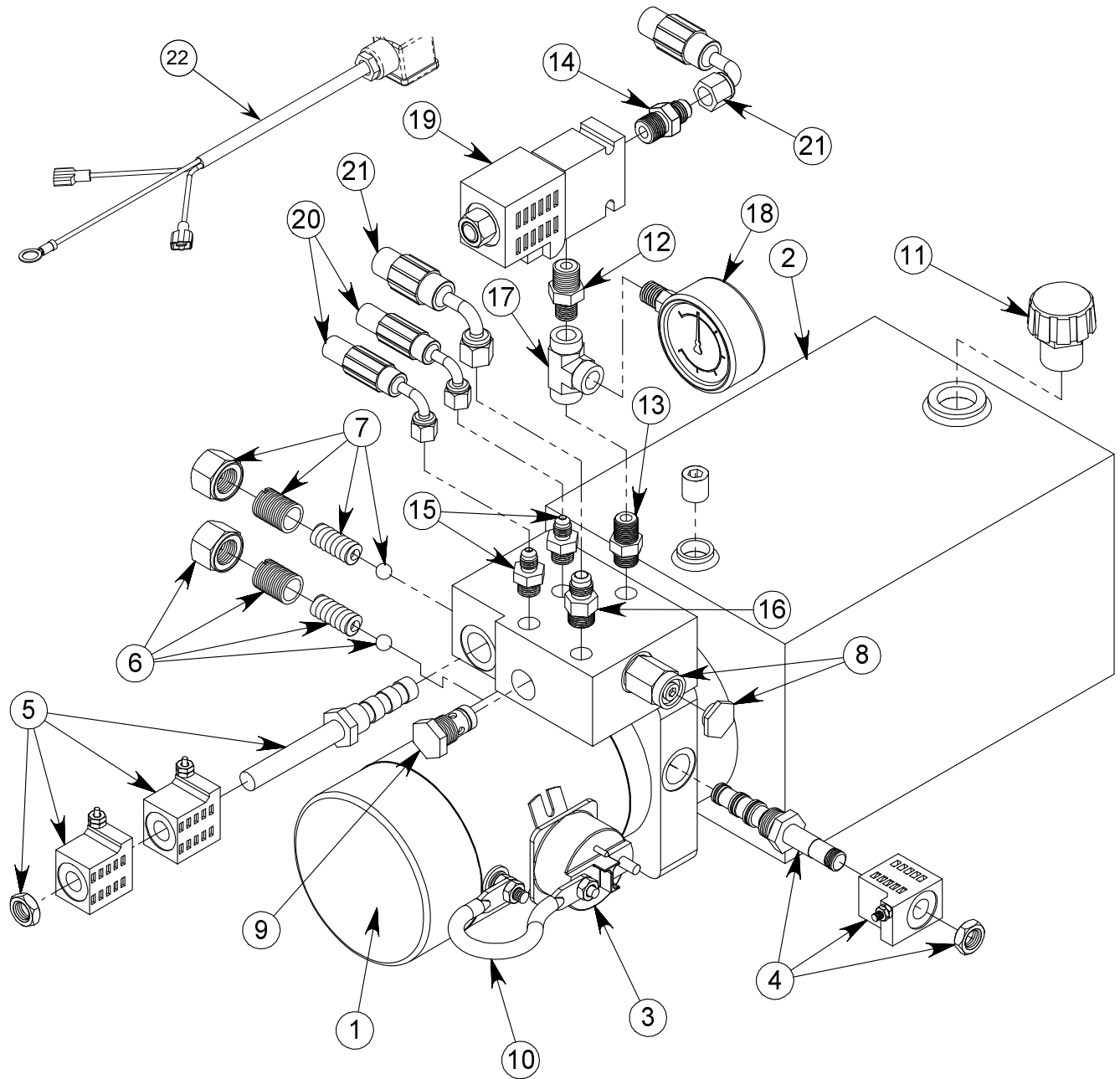

ITEM #	DESCRIPTION	PART #	QTY	ITEM #	DESCRIPTION	PART #	QTY
	POWER UNIT ASSEMBLY	68030	1	12	FITTING, ¼ NPTM X 3/8 NPTM	20672	1
1	MOTOR	25163	1	13	FITTING, ¼ NPTM X 9/16 O'RING	68049	1
2	RESERVOIR	68234	1	14	FITTING, 3/8 NPTM X 3/8 JICM	68055	1
3	SOLENOID, 12VDC	16637	1	15	FITTING, ¼ JICM X 9/16 O'RING	68056	2
4	VALVE, 4W2P, CARTRIDGE	68224	1	16	FITTING, 3/8 JICM X 9/16 O'RING	68057	1
5	VALVE, 4W3P, CARTRIDGE	68225	1	17	FITTING, ¼ NPTF TEE	68058	1
6	VALVE, RELIEF, MAIN	68226	1	18	PRESSURE GAUGE	68061	1
7	VALVE, RELIEF, POWER DOWN	68227	1	19	VALVE, BI DIRECTION LOCK	68149	1
8	VALVE, RELIEF, POC	68230	1	20	HOSE, ½" JICF	68392	2
9	VALVE, P.O. CHECK	69076	1	21	HOSE, 3/8" JICF	68393	2
10	CABLE, SOLENOID	10022	1	22	DIN CONNECTOR ASBLY	20879	1
11	FILLER CAP	20979	1				

**Hydraulic Power Unit Assembly – Dual Motor (Lifts Built before 3/30/2006)**

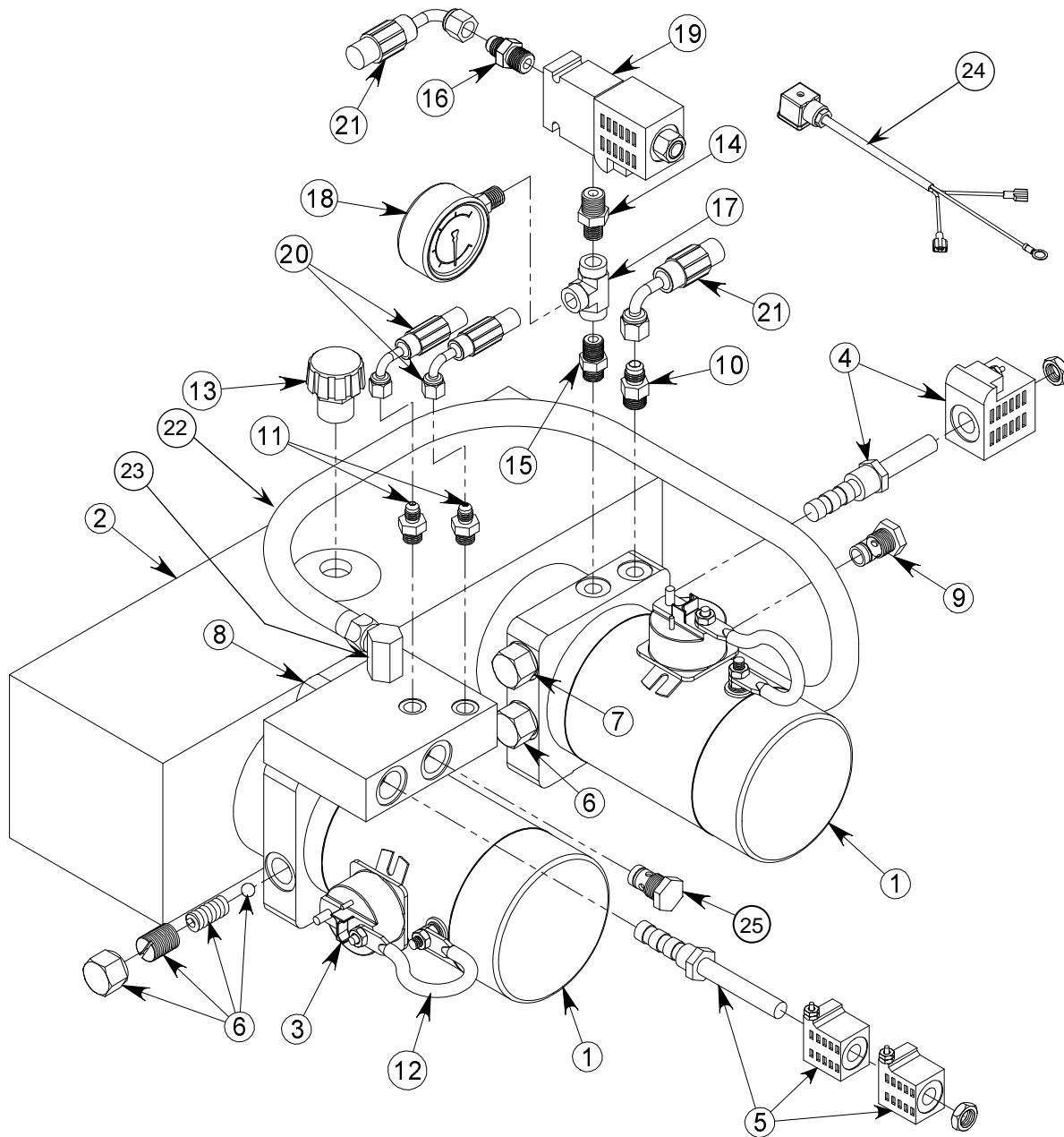

ITEM #	DESCRIPTION	PART #	QTY	ITEM #	DESCRIPTION	PART #	QTY
	POWER UNIT ASSEMBLY	68839	1	13	FILLER CAP	20979	1
1	MOTOR	25163	2	14	FITTING, ¼ NPTM X 3/8 NPTM	20672	1
2	RESEVOIR	68629	1	15	FITTING, ¼ NPTM X 9/16 O'RING	68049	1
3	SOLENOID, 12VDC	16637	2	16	FITTING, 3/8 NPTM X 3/8 JICM	68055	1
4	VALVE, 4W2P, CARTRIDGE	68043	1	17	FITTING, ¼ NPTF TEE	68058	1
5	VALVE, 4W3P, CARTRIDGE	68225	1	18	PRESSURE GAUGE	68061	1
6	VALVE, RELIEF, MAIN	68226	1	19	VALVE, BI DIRECTION LOCK	68149	1
7	VALVE, RELIEF, POWER DOWN	68227	1	20	HOSE, ¼"	68392	2
8	VALVE, RELIEF, POC	69077	1	21	HOSE, 3/8" JICF	68393	2
9	VALVE, CHECK	25477	2	22	HOSE, CONNECTING, 3/8"	68768	1
10	FITTING, 3/8 JICM X 9/16 O'RING	68057	1	23	FITTING, 3/8, 90 deg. swivel	68769	2
11	FITTING, ¼ JICM X 9/16 O'RING	68056	2	24	DIN CONNECTOR ASBLY	20879	1
12	CABLE, SOLENOID	10022	2	25	VALVE, P.O. CHECK	69076	1

**Hydraulic Power Unit Assembly – Dual Motor**

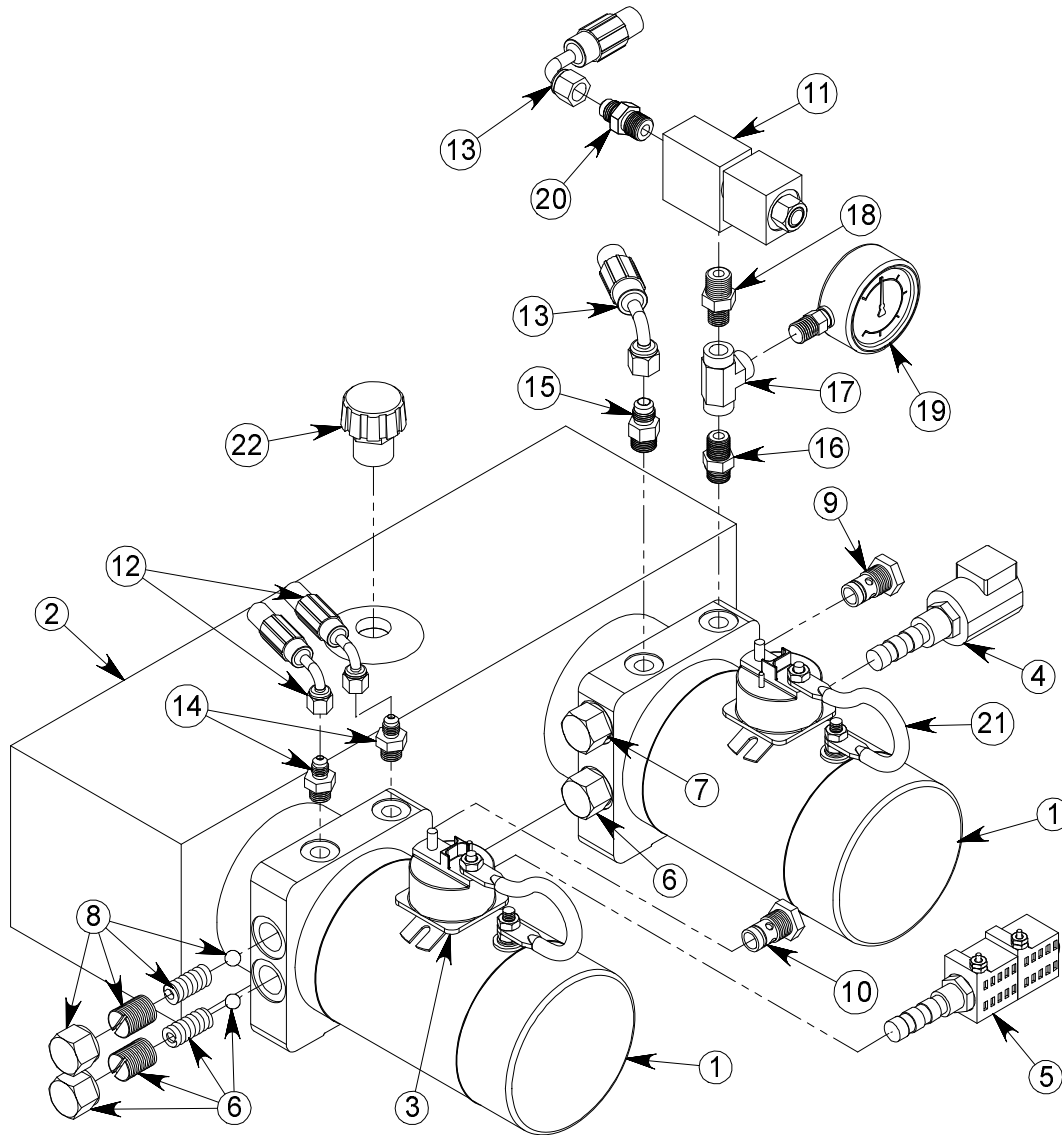

ITEM #	DESCRIPTION	PART #	QTY	ITEM #	DESCRIPTION	PART #	QTY
	POWER UNIT ASSEMBLY	69088	1	12	HOSE, ¼" JICF	68392	2
1	MOTOR	25163	2	13	HOSE, 3/8" JICF	68393	2
2	RESEVOIR	69107	1	14	FITTING, ¼ JICM X 9/16 O'RING	68056	2
3	SOLENOID, 12VDC	16637	2	15	FITTING, 3/8 JICM X 9/16 O'RING	68057	1
4	VALVE, 4W2P, CARTRIDGE	69098	1	16	FITTING, ¼ NPTM X 9/16 O'RING	68049	1
5	VALVE, 4W3P, CARTRIDGE	68225	1	17	FITTING, ¼ NPTF TEE	68058	1
6	VALVE, RELIEF, MAIN	68226	2	18	FITTING, ¼ NPTM X 3/8 NPTM	20672	1
7	VALVE, RELIEF, POWER DOWN	68227	1	19	PRESSURE GAUGE	68061	1
8	VALVE, RELIEF, POC	69077	1	20	FITTING, 3/8 NPTM X 3/8 JICM	68055	1
9	VALVE, CHECK	69108	1	21	CABLE, SOLENOID	10022	2
10	VALVE, P.O. CHECK	69109	1	22	FILLER CAP	20979	1
11	VALVE, BI DIRECTION LOCK	68149	1				

**Decals**

Properly placed warning decals are an essential part of your safety program. Check that all safety decals are in place and are legible. Any missing decals **MUST** be replaced immediately. Replacement decals may be obtained **FREE** of charge from your distributor or by phoning, writing, or faxing us.

Following are the proper decals that you should have and their proper locations:

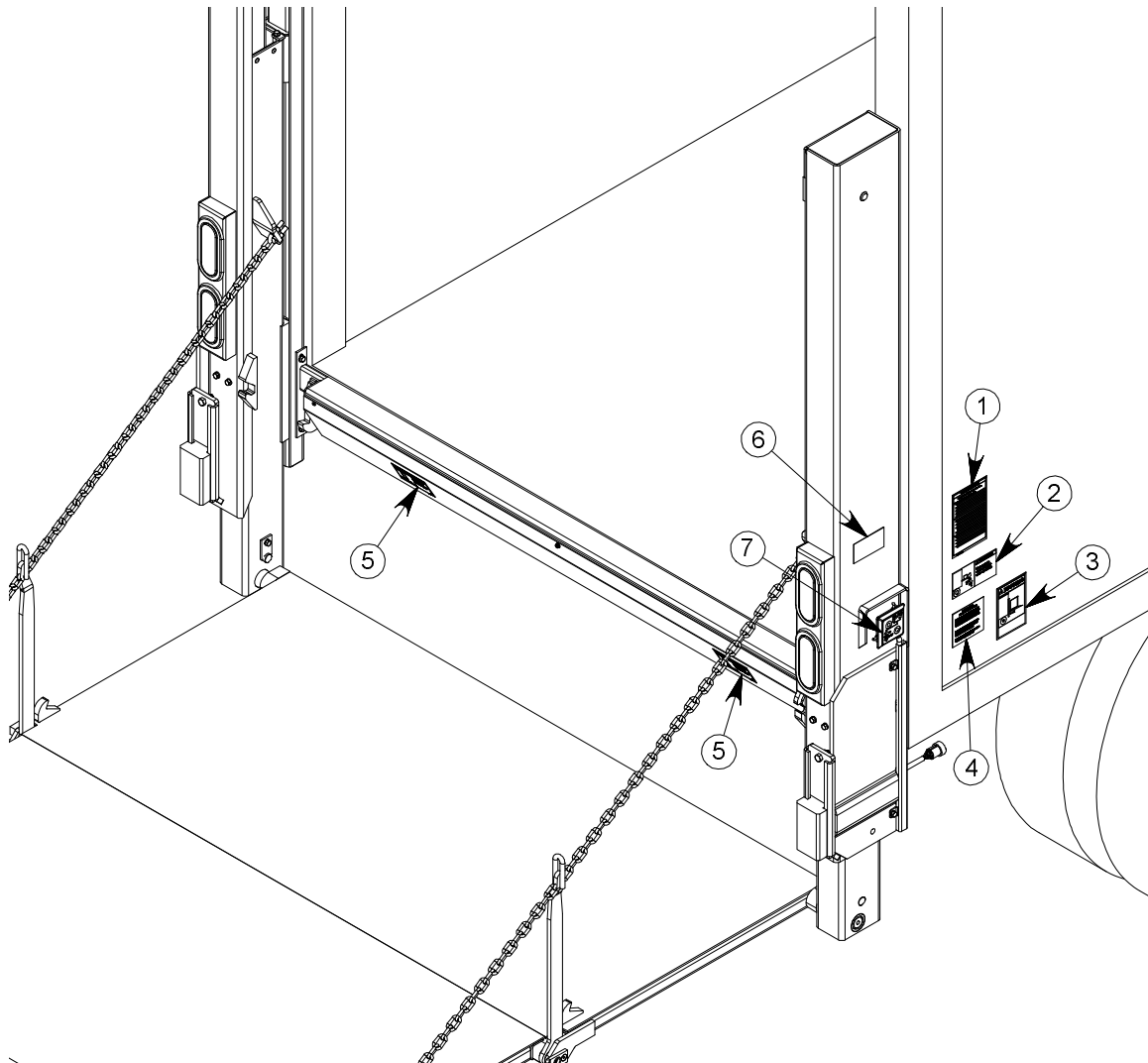

ITEM #	DESCRIPTION	DV45	DV55	DV66	QTY
1	OPERATING INSTRUCTIONS		68845		1
2	WARNING, KEEP CLEAR		20425		1
3	WARNING, MAX. CAPACITY	68217	68847	20875	2
4	URGENT WARNING		16181		1
5	DANGER, LIFTGATE CAN CRUSH		16184		2
6	SAFETY, OPEN AND CLOSE		68683		1
7	OPEN AND CLOSE DECAL		68945		1

## Help and Service

With careful maintenance and operation your **Ultron** liftgate should give you years of trouble free use. If a problem does develop, contact your liftgate distributor. They are best equipped to service your liftgate.

If you have suspected warranty problems, contact the distributor from whom you purchased the liftgate. They will normally process your claim from start to finish.

Your distributor will repair your liftgate and get you on the road as quickly as possible. They may invoice you for this service. If the problem is found to be warrantable by Ultron Lift Corp., Ultron liftgates will issue your Distributor a credit, which should then be credited back to you.