

# Rail Style Liftgates

Read Before Installing

## INSTALLATION MANUAL

For Series: DL, DS, DT, GB, HD

# Ultron

**Ultron Lift Corporation**

190 Lewis St. PO Box 6126  
Buffalo, NY 14240-61 26 USA

(716) 853-7994

US & Canada 800-289-1335

12 Industrial St.  
Toronto, ON M4G 1Y9 Canada  
(416) 421-7987

[www.ultronlift.com](http://www.ultronlift.com)

## For Your Safety

This Manual follows the Guidelines set forth in ANSI Z535.4-1998 for alerting you to possible hazards and their potential severity.



This is the safety alert symbol. This manual uses this symbol to alert you to potential personal injury hazards. Obey all safety messages that follow this symbol to avoid possible injury or death.



**DANGER** indicates an imminently hazardous situation which, if not avoided, will result in death or serious injury.



**WARNING** indicates a potentially hazardous situation which, if not avoided, could result in death or serious injury.



**CAUTION** indicates a potentially hazardous situation which, if not avoided, may result in minor or moderate injury.



**CAUTION** used without the safety alert symbol indicates a potentially hazardous situation which, if not avoided, may result in property damage.

## Memo To The Installer



### WARNING

1. Improper installation and use of this liftgate may result in serious injury or death
2. Make sure that you are properly trained and qualified before you install this liftgate.
3. Make sure you read and understand this manual before you install this liftgate.

Please call us if you have any questions during this installation.

- USA: 800-289-1335
- Canada: 416-421-7987
- Monday through Friday, 8 A.M. to 5 P.M., Eastern Time

We are committed to:

- Helping you install this liftgate safely and correctly
- Providing your customer with a durable, trouble-free, long-lasting liftgate

Remember, we're on your team!

Thank you for choosing our liftgates.

Sincerely,

Quick Response Team

Ultron Lift Corporation





## WARNING

1. **READ AND UNDERSTAND** installation instructions for installing this liftgate.
2. Failure to follow all instructions may result in severe personal injury or death.
3. Do not attempt this installation if you are not a qualified trained welding technician with appropriate training in liftgate installation.
4. Do not install truck lights if you are not properly trained in truck electrical equipment.

1. NEVER stand under or near the liftgate when the liftgate is being raised or positioned for installation.  
This liftgate can crush persons, causing death or severe injuries.
2. ALWAYS disconnect the truck's positive and negative battery cables to avoid damage to the truck's electrical system.  
Follow the procedures in the Vehicle Owner Manual.
3. ALWAYS turn the Master Disconnect switch to OFF when leaving the truck unattended.
4. ALWAYS lock cab doors to prevent unauthorized use of the liftgate.
5. ALWAYS affix safety decals according to these instructions.
6. ALWAYS perform final inspection after installation.
7. ALWAYS read the Operator's Manual before testing or operating this liftgate.
8. ALWAYS inspect your installation and complete the Final Inspection Checklist after finishing the installation.
9. ALWAYS follow the procedures in this Manual to install the Master Disconnect Switch and the Circuit Breaker.
10. ALWAYS install the Master Disconnect Switch and Circuit Breaker before reconnecting the truck's battery cables.
11. NEVER install the Master Disconnect Switch and Circuit Breaker if you are not properly trained in truck electrical equipment.

# TABLE OF CONTENTS

- For Your Safety ..... 1
- Memo To The Installer ..... 2
- About This Liftgate ..... 5
- 1. PREPARE FOR INSTALLATION ..... 7**
  - 1.1 Before You Start ..... 7
  - 1.2 Check Mounting Requirements ..... 8
  - 1.3 Check For Parts ..... 9
  - 1.4 Tools Required ..... 11
  - 1.5 Prepare the Truck Body ..... 12
  - 1.6 Special Instructions for Flat Beds and Stake Bodies..... 13
  - 1.7 Special Instructions for Van Bodies with Aluminum or  
Fiberglass Corner ..... 14
- 2. ATTACH THE LIFTGATE ..... 16**
  - 2.1 Position the Liftgate..... 16
  - 2.2 Weld the Liftgate to the Truck ..... 18
  - 2.3 Cut Off Excess Track ..... 19
  - 2.4 Reinforce the Liftgate Mounting ..... 20
  - 2.5 Special Adjustments for Above-Floor-Bed Lifts ..... 21
  - 2.6 Install Remote Power Unit Box (Power Open and Close).....22a
- 3. INSTALL ELECTRICAL COMPONENTS ..... 23**
  - 3.1 Install Master Disconnect Switch ..... 23
  - 3.2 Install the Circuit Breaker ..... 25
  - 3.3 Secure The Cables ..... 27
  - 3.4 Wire Lights ..... 28
- 4. TEST THE LIFTGATE OPERATION ..... 29**
- 5. COMPLETE THE INSTALLATION ..... 30**
  - 5.1 Affix Warning Decals ..... 30
  - 5.2 Operator’s Manual..... 31
  - 5.3 Final Test ..... 32
  - 5.4 Inspect Your Installation and Document Your Inspection ..... 33
    - Inspection Sheet ..... 34

## About This Liftgate

### DESCRIPTION

The model DL, DS, DT, GB, and HD liftgates are 100% level-ride, rail-style liftgate that are available in capacities ranging from 1250 pounds to 4000 pounds.

Rail-style liftgates have two rails mounted to the rear of a truck by either welding or bolting. These rails, also called tracks, support a platform which raises and lowers cargo.



**Liftgate, Installed**

The **DL Series** liftgate come in four basic models:

- DL12 -capacity: 1250 lbs, DL16 -capacity: 1600 lbs
- DL20 -capacity: 2000 lbs, DL30— capacity: 3000 lbs

Each model is available in an above-floor model, indicated by **AF** at the end of the model number.

---

The **DS Series** liftgate come in three basic models:

- DS16 -capacity: 1600 lbs, DS20 -capacity: 2000 lbs and DS30— capacity: 3000 lbs.

Each model is available in an above-floor model, indicated by **AF** at the end of the model number.

---

The **DT Series** liftgate come in three basic models:

- DT16 -capacity: 1600 lbs, DT20 -capacity: 2000 lbs and DT30— capacity: 3000 lbs.
- 

The **GB Series** liftgate come in three basic models:

- GB16 -capacity: 1600 lbs, GB20 -capacity: 2000 lbs and GB30— capacity: 3000 lbs.

Each model is available in an above-floor model, indicated by **AF** at the end of the model number.

---

The **HD Series** liftgate come in three basic models:

- HD20 -capacity: 2000 lbs, HD30— capacity: 3000 lbs. and HD40— capacity: 4000 lbs.
- 

### THEORY OF OPERATION

The rail-type liftgate is designed to lift cargo vertically from the truck bed to the ground or dock, and vice-versa. Power is provided by a hydraulic power unit and cylinder that activates a chain and sprocket system. Activation of a control switch supplies current from a 12-volt battery to the hydraulic power unit. The hydraulic power unit in turn supplies pressurized hydraulic fluid to the hydraulic cylinder. The cylinder extends, tensioning the chains which are attached to the platform. The resultant upward pull on the platform raises it.

The platform is lowered by gravity. Activation of the control switch releases the hydraulic fluid back to the power unit from the cylinder. The cylinder retracts, releasing the tension on the chain, and the platform lowers by its own weight.

**DESIGN DETAIL**

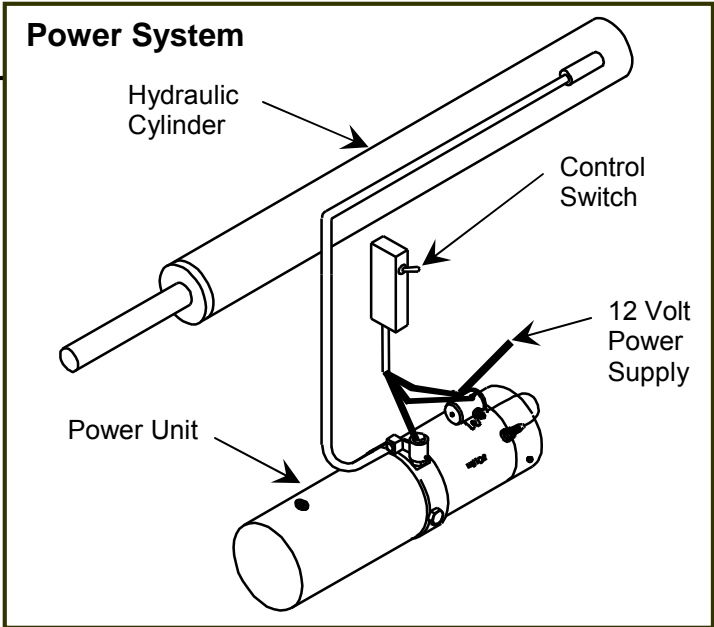
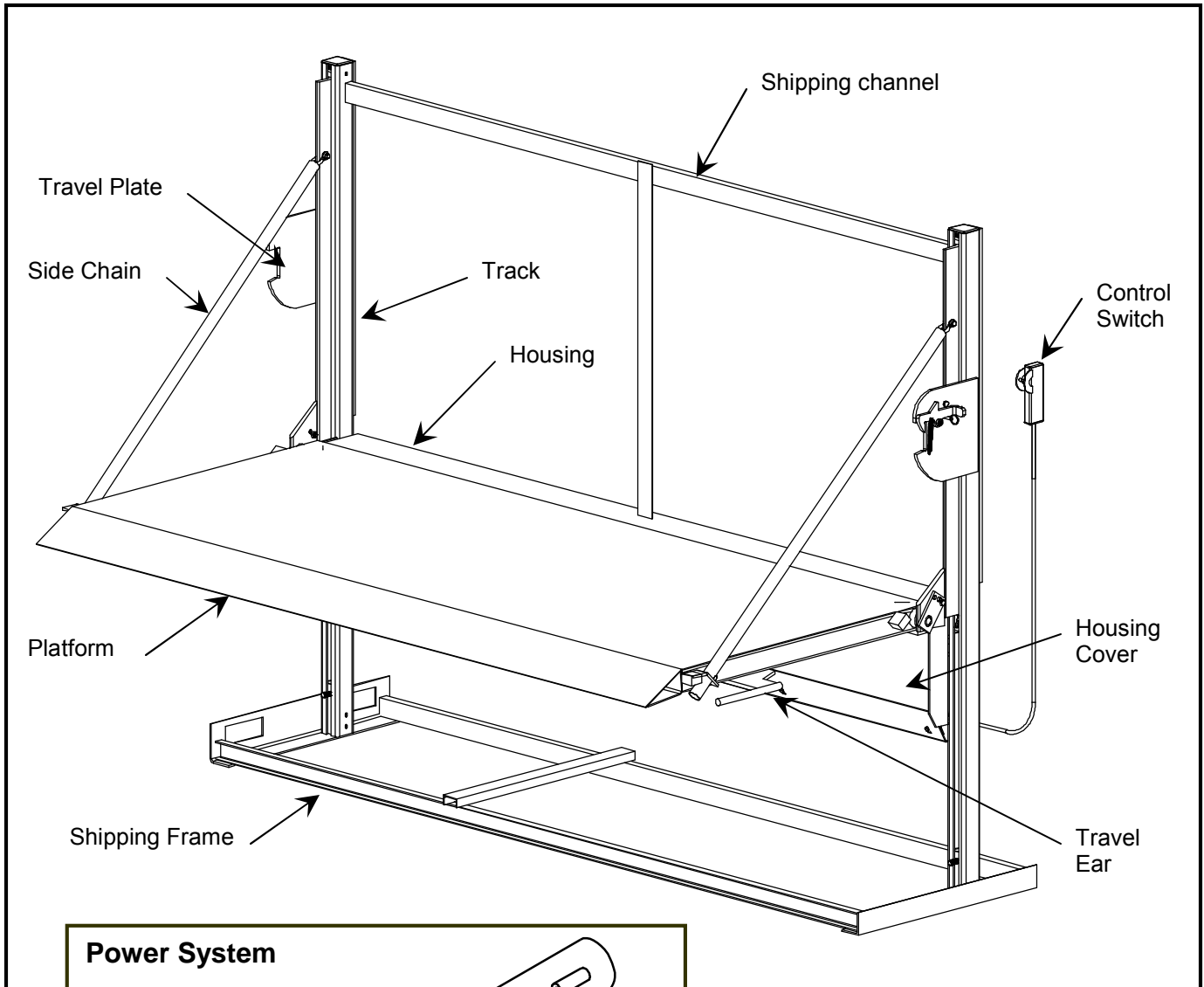

# 1. PREPARE FOR INSTALLATION

## 1.1 Before You Start



### WARNING

1. Liftgate can crush.
2. DO NOT INSTALL this liftgate if you do not understand all procedures.
3. Improper installation of the liftgate may result in severe personal injury or death.

Call Customer Service for assistance:

USA: 800-289-1335

Canada: 416-421-7987

**STEP 1** Check the Model type (DL, DS, DT, GB, HD).

**STEP 2** Read this Installation Manual.

**STEP 3** Become familiar with:

- The liftgate
- The components in the Electrical Component Kit
- The Safety Decal Kit

## 1.2 Check Mounting Requirements

### STEP 1 Determine clearance requirements.

#### Measure Dimensions A and B (Bed Height)

- a) Outside width of liftgate should match dimension A
- b) Dimension B is the truck bed height.
  - i) Maximum bed height (measured with vehicle empty) must be within the range shown in the chart below.

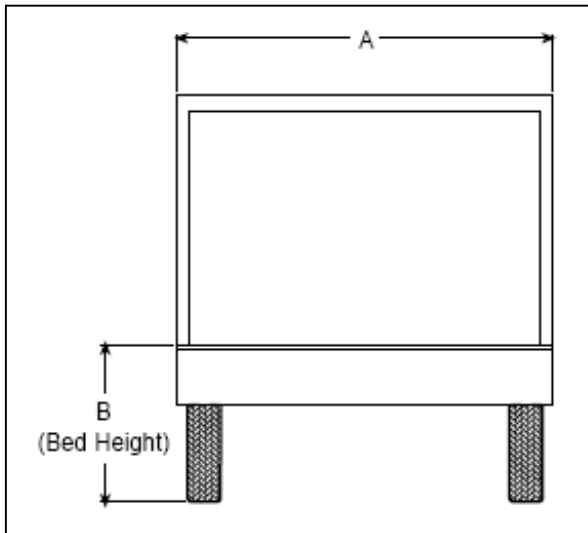

#### Clearance Dimensions

| Model                             | A           | B       |
|-----------------------------------|-------------|---------|
| DL12                              | 78" and 94" | 30"-46" |
| DL16, DL20, DL30                  | 94"         | 30"-56" |
| DS with 36" platform              | 94"         | 38"-57" |
| DS with 42" platform              | 94"         | 42"-57" |
| GB                                | 94"         | 36"-57" |
| HD20/30 with 36" or 42" platform. | 94"         | 30"-57" |
| HD with 48" platform and greater. | 94"         | 36"-57" |

### STEP 2 Determine wall requirements.

Truck body must be capable of supporting minimum forces shown in

#### Side Wall Requirements.

- X = side wall tension - 1500 lbs.
- Y = side wall compression - 1500 lbs.
- Z = side wall shear - 1500 lbs.

#### HD40 Models:

- X = side wall tension - 2500 lbs.
- Y = side wall compression - 2500 lbs.
- Z = side wall shear - 2500 lbs.

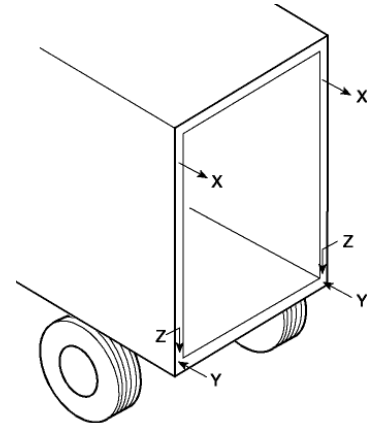

Side Wall Requirements

- STEP 3** Ensure truck body door does not interfere with installation or operation of liftgate. Rail Lift style liftgates cannot be installed with "barn" or "swing" type doors without extensive modification.

**Consult Customer Service for assistance or if you are not sure your vehicle meets the requirements.**

## 1.3 Check For Parts

**STEP 1** Make sure you have all the parts listed below as well as all **Liftgate parts** (See Design Detail, pg. 6). Check these parts and the liftgate assembly for shipping damage. Call Customer Service if any parts are missing or defective.  
USA: 800-289-1335 • Canada: 416-421-7987

### ELECTRICAL COMPONENT KIT

- Master Disconnect Switch with plate
- Circuit breaker
- 2 circuit breaker mounting screws
- 9 plastic nylon ties
- Two #2 x 3/8" copper lugs
- Two #2 x 1/4" copper lugs
- 4 heat-shrink tubes
- 9 frame clips

### AF MODELS ONLY

- 2 extra master links

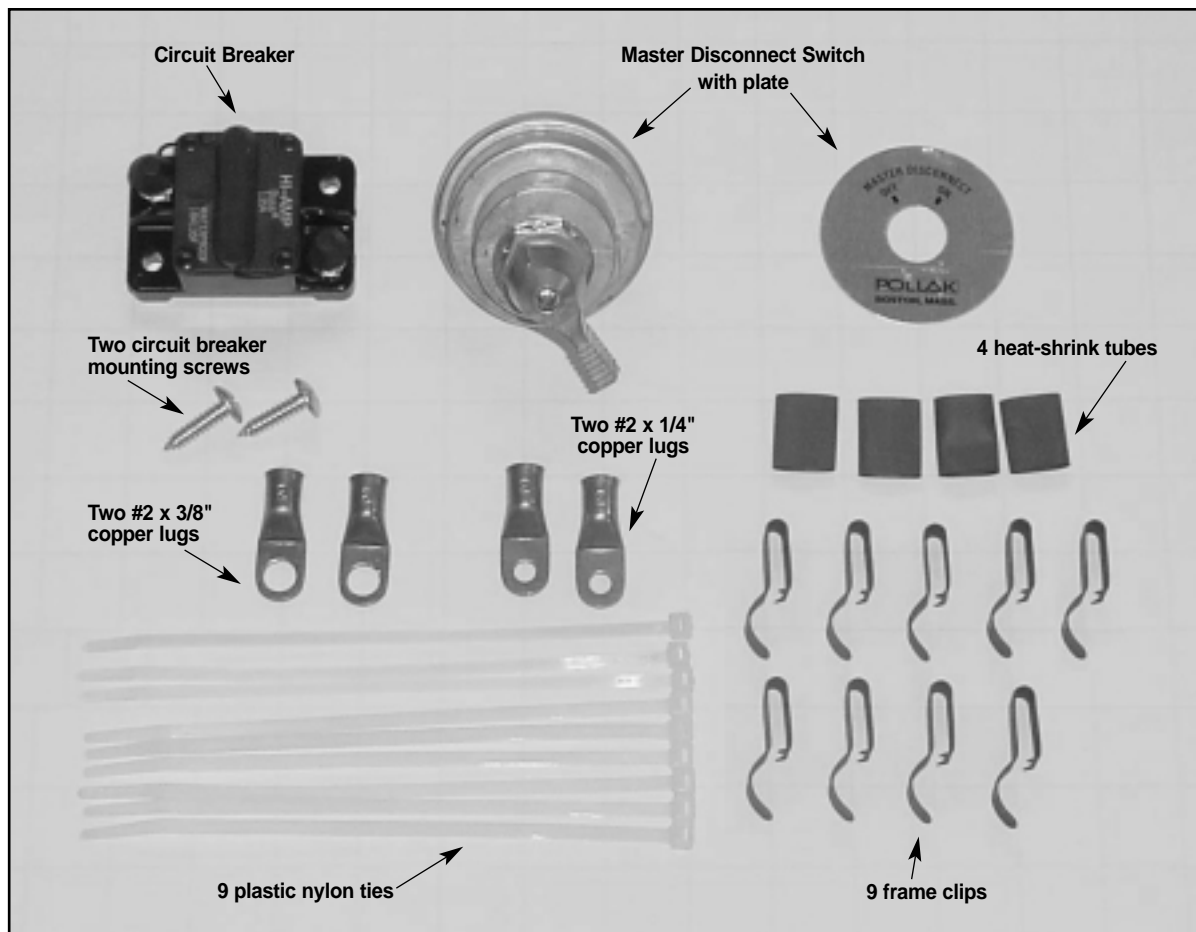

**STEP 2** Make sure you have all the parts listed below.

Check these parts for shipping damage.

Call Customer Service if any parts are missing or defective.

USA: 800-289-1335 Canada: 416-421-7987

**SAFETY DECAL KIT**

- Urgent Warning: Elevating Gate Instructions
- 2 decals, Danger Message: Liftgate can crush.
- 1 decal, Warning Message: Keep people clear of liftgate while operating.
- 1 decal, Warning Message: Avoid riding liftgate.
- 2 decals, Maximum Capacity

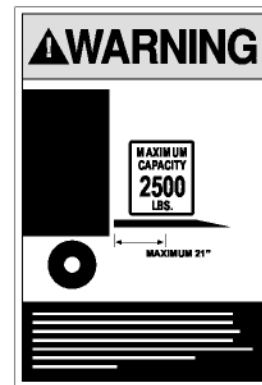
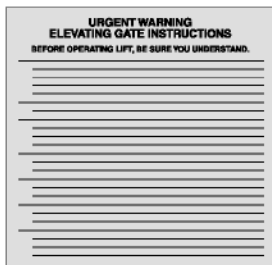

**INSTALLATION MANUAL**

**OPERATOR'S MANUAL KIT**

- Operator's Manual

**STEP 3** Check for shipping damage.

**STEP 4** Put the Operator's Manual in the glove box.

**STEP 5** Put decals in secure place for later installation.

## 1.4 Tools Required

- STEP 1** Make sure you have the following tools, equipment, and materials available:
- Chalk or other marking device
  - Wrenches
  - Cutting torch
  - Two 10" C-clamps
  - Lifting device: floor jack, forklift, or crane
  - Drill & drill bits (1/4 ", 5/16", and 3/4 ")
  - Grinder
  - Reciprocating saber saw ("Sawzall" or equivalent)
  - Welding machine
  - Square 24"
  - Tape measure

# 1.5 Prepare the Truck Body

**STEP 1** Remove any object from the rear of the vehicle that may interfere with the liftgate.

**STEP 2** Locate and mark the center of the vehicle floor and rear sill.  
**Note:** This mark will be used for centering the liftgate.

**STEP 3** Check the corner posts and add spacers if corner posts are not flush with rear sill.

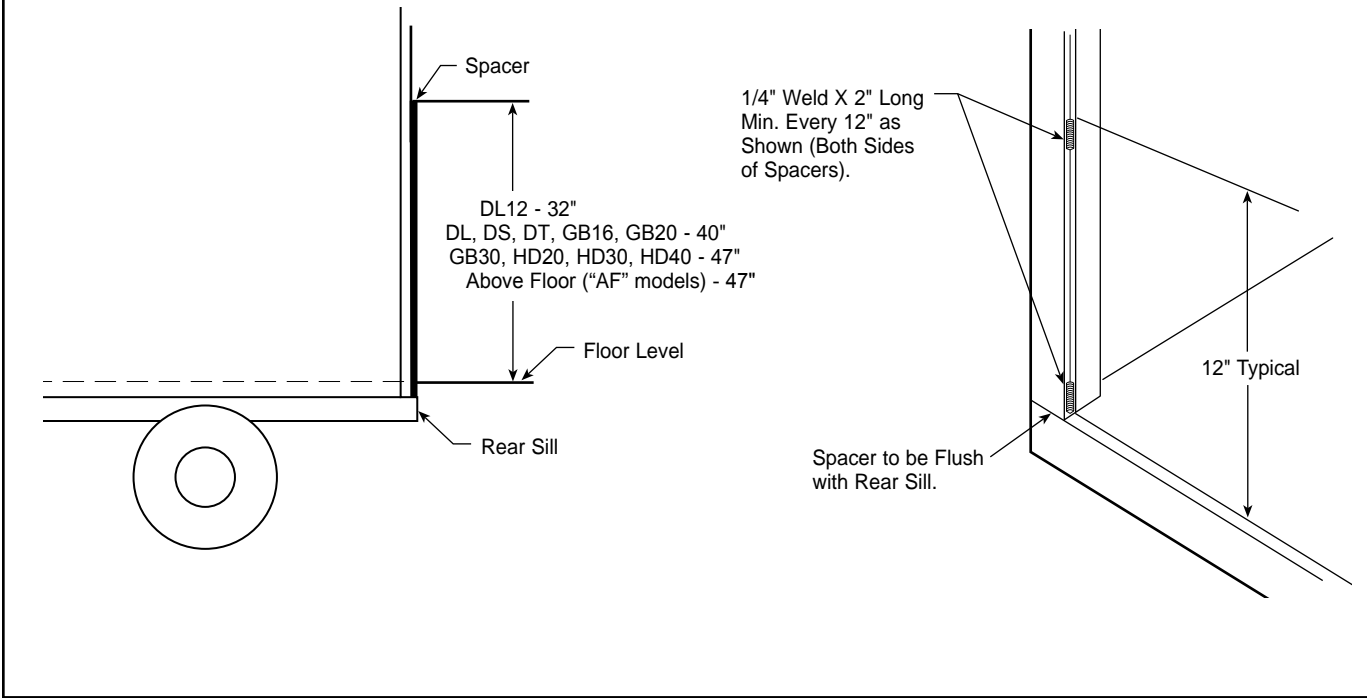

**1.6 Special Instructions for Flat Beds and Stake Bodies**

**STEP 1** Fabricate and install support tubes and braces as shown in **Flat Bed Installation** and **Fasten Plate to Side Rail**.

**Flat Bed Installation**

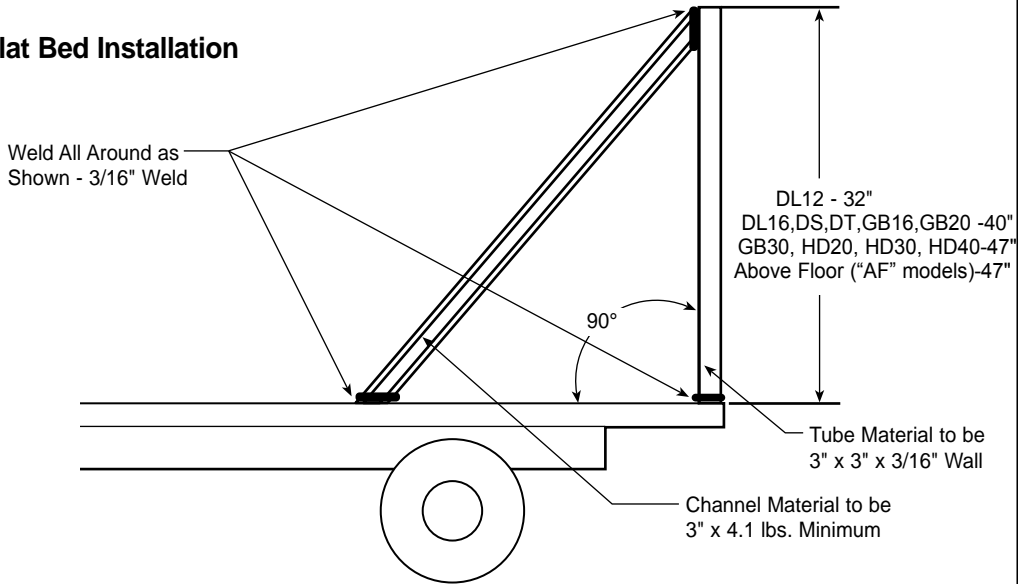

**STEP 2** If the side rail of the vehicle is less than 1/4" thick:

- Bolt or weld a 1/4" plate to side rail first.
- Weld channel to plate.

**Fasten Plate to Side Rail**

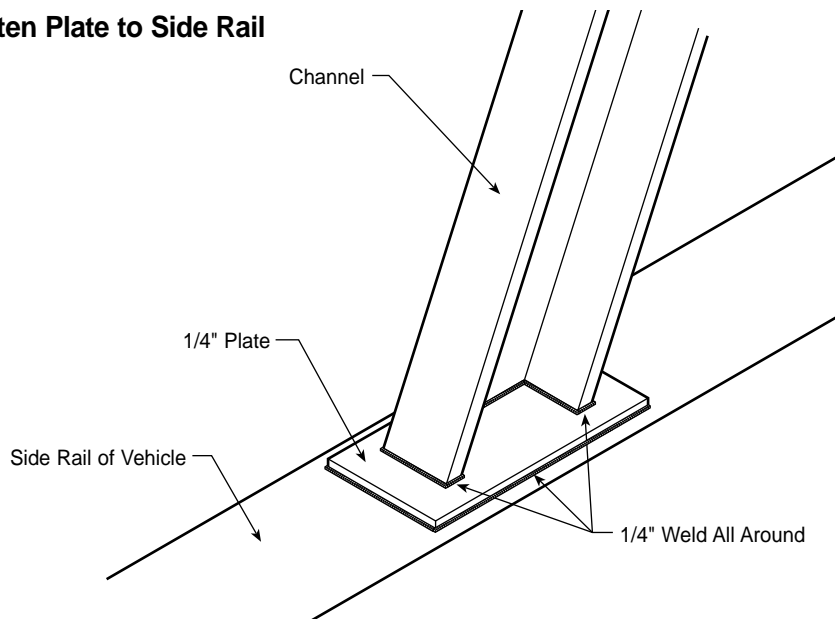

**1.7 Special Instructions for Van Bodies with Aluminum or Fiberglass Corner Posts**

**STEP 1** If body has fiberglass corner posts, call Customer Service.

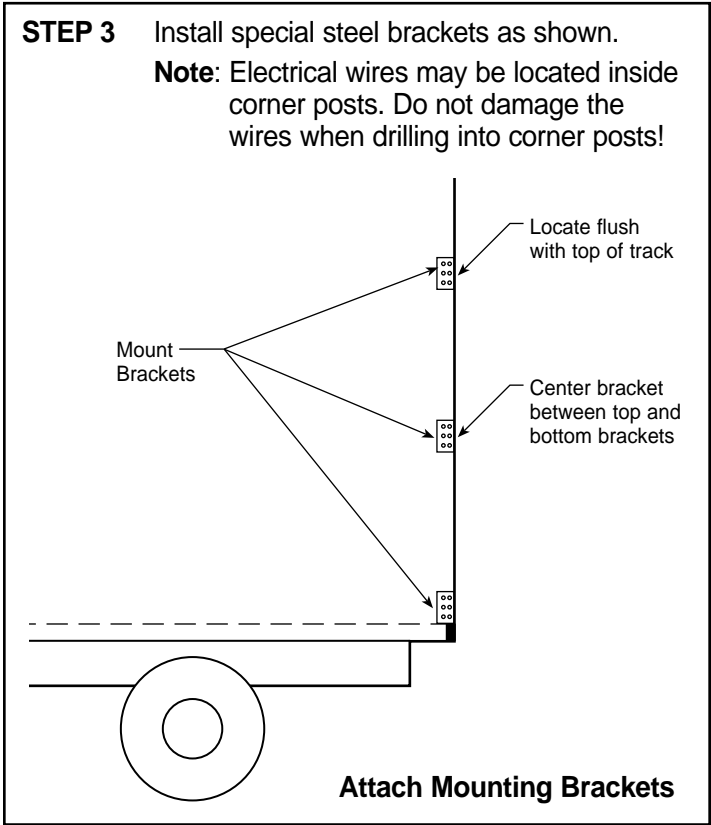
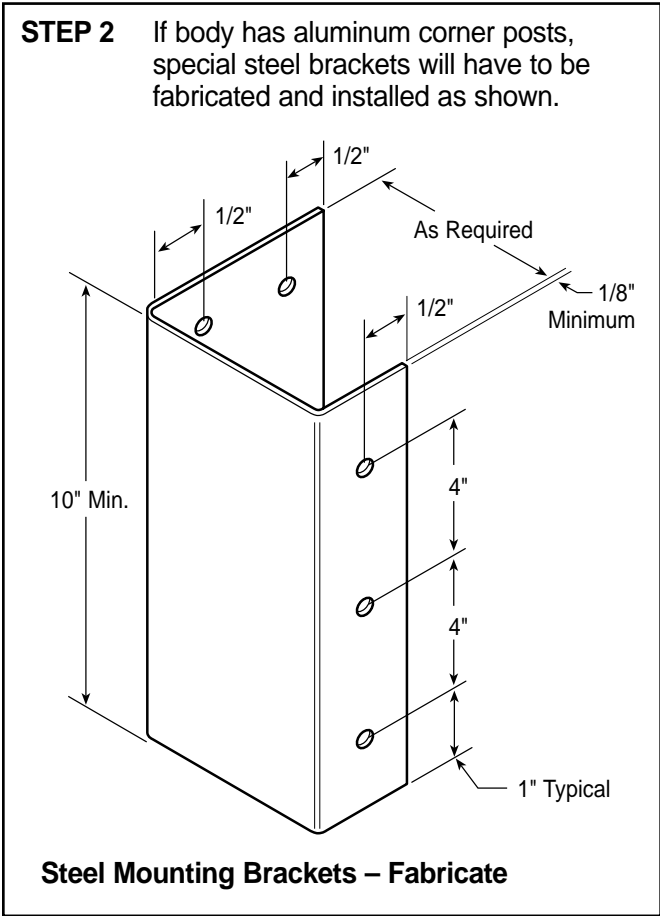

**STEP 4** After installing mounting brackets, check to see if mounting brackets are flush with the rear sill.  
Add spacers to mounting brackets or build out rear sill, if necessary.

**Add Spacers to Mounting Brackets**

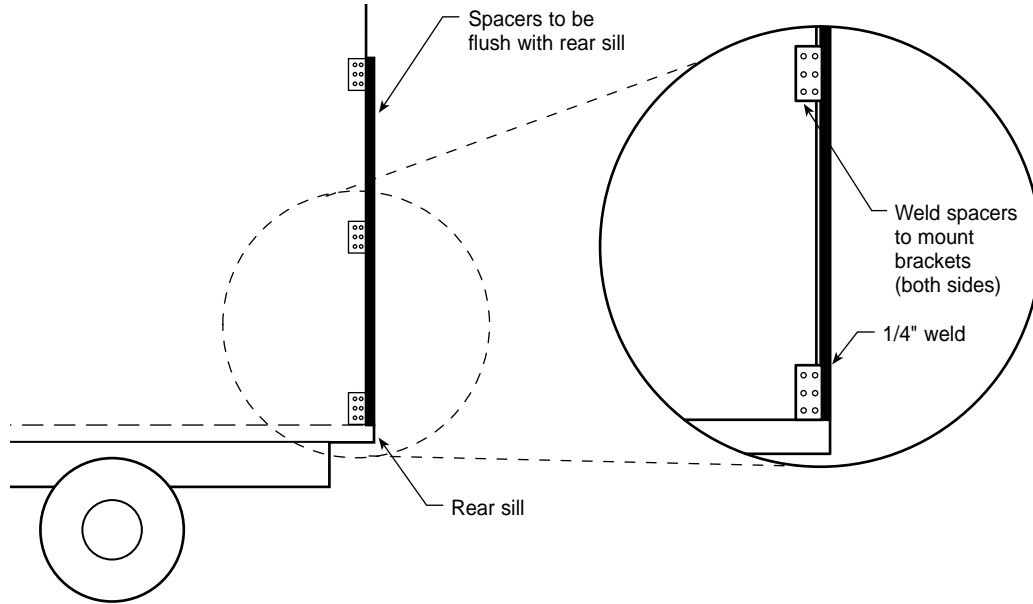

**Build Out Sill**

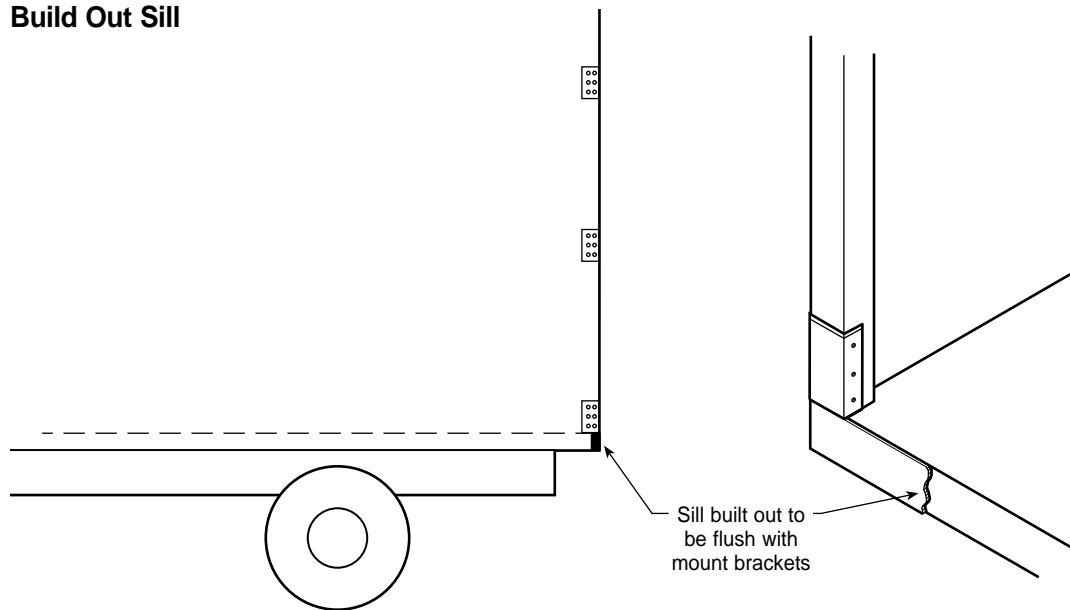

## 2. ATTACH THE LIFTGATE

### 2.1 Position the Liftgate



#### CAUTION

Make sure that battery cables are disconnected before welding to avoid damaging the truck's electrical system.

- STEP 1** Use a forklift to position the liftgate in the work area.
- The side to be welded to the truck should face the rear of the truck.

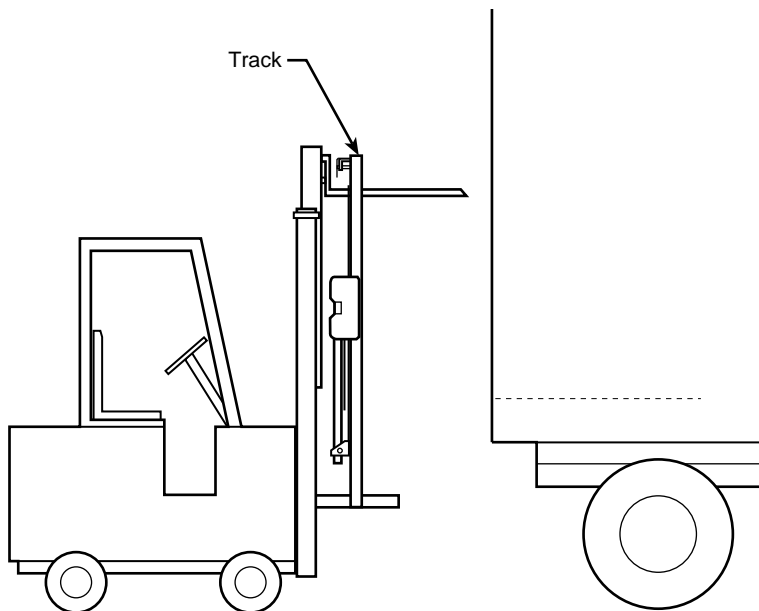

- STEP 2** Uncoil battery cables and cable for light wires.
- Note!** Your liftgate is assembled. The cables are prefastened to the liftgate.

- STEP 3** Lay the cables along the length of the truck so power can be hooked up later in installation.

- STEP 4** Put the electrical component kit aside for later installation.

- STEP 5** Attach chains or hooks to the lifting bar.

- STEP 6** Use an adequate lifting device to raise the liftgate to the height of the floor of the truck bed.
- Recommended lifting devices:
- Chain fall
  - Forklift
  - Overhead crane

- STEP 7** Line up center of liftgate housing with center of truck bed.

- STEP 8** Check that the top of the liftgate housing is level with the rear sill of the truck. Check the tracks for squareness using a square as shown.

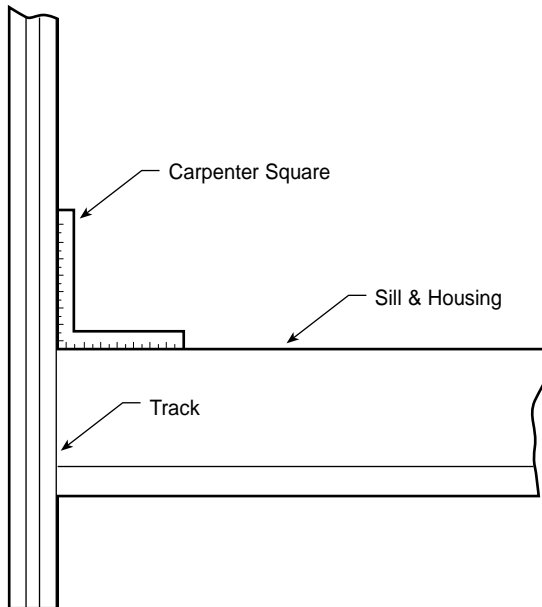

- STEP 10** Use the 10-inch C-clamps to fasten the liftgate to the truck
- Make any necessary adjustments to C-clamps before welding

- STEP 11** Re-check for squareness. DO NOT WELD until you are sure that:
- The top of the liftgate housing is level with the truck floor
  - Tracks are square
  - The liftgate is centered between both sides of the opening.

**Note!** Do not remove the lifting device yet!

- STEP 9** Double check tracks for squareness using the diagonal measurements as shown. This is essential to ensure the smooth operation of the lift.

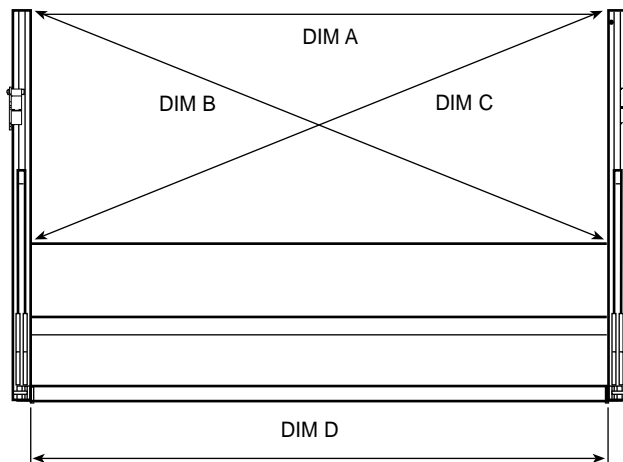

**Check Squareness with Horizontal & Diagonal Measurements**

**Check Dim A = Dim D, DIM B = DIM C**

## 2.2 Weld the Liftgate to the Truck

**STEP 1** Weld the liftgate directly to the reinforcing corner plate.

**STEP 2** Weld the outside of track to the truck.

**STEP 3** Supply temporary power to the liftgate using a 12-volt battery source.

**STEP 4** Open the platform so that you can weld the inside of the liftgate.

**STEP 5** Lower the liftgate by pressing the toggle switch down.

**STEP 6** Weld inside of tracks to reinforcement plates.

**STEP 7** Weld top of housing to sill of truck.

**STEP 8** Remove clamps.



### WARNING

Do not remove clamps until you are sure liftgate is securely welded to truck.

**STEP 9** Remove the lifting device.

**STEP 10** Remove shipping frame.  
Set aside - you will use channels later in reinforcing the liftgate mounting (2.4).

**STEP 11** Remove lifting bar.  
Set the lifting bar aside – you will use it later to attach the bottom of the rail to the truck (2.4).

**STEP 12** Grind top of weld.

## 2.3 Cut Off Excess Track

**STEP 1** Trim tracks, if necessary, to provide adequate ground clearance.  
**Maximum Distance** between bottom of truck and ground must be no more than the following, after cutting:

DL12- 15"  
 DL, DS, DT, GB, HD - 20"

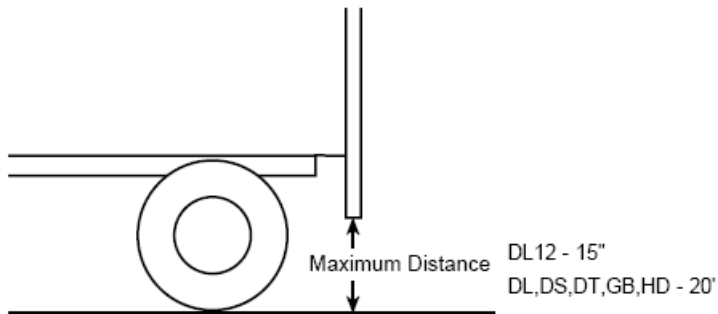

**STEP 2** Deburr tracks after cutting by grinding inside and outside edges smooth. **Deburr inside back bottom of left and right hand tracks with 3/16 chamfer or radius.**

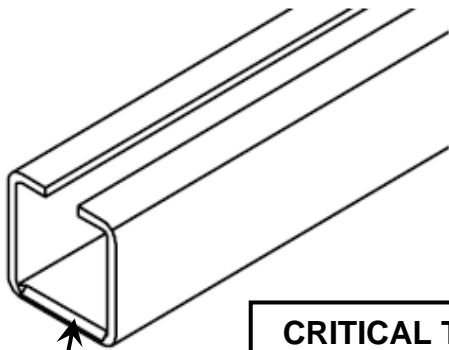

**CRITICAL TO SMOOTH OPERATION.**  
 Deburr inside back bottom of left and right hand tracks with 3/16 chamfer or radius.

## 2.4 Reinforce the Liftgate Mounting



**CAUTION** Make sure that battery cables are disconnected before welding to avoid damaging the truck's electrical system.

**STEP 1** Retrieve the Shipping Frame previously removed. Cut channel into two 6" length. Weld these two channels from the bottom of the liftgate to the frame of the truck as shown.

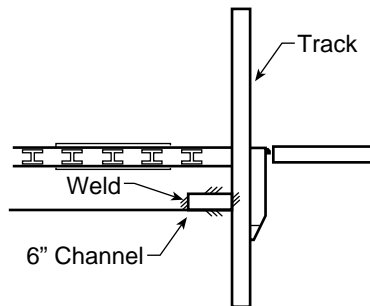

**STEP 2** Retrieve the Lifting Bar previously removed. Cut into two lengths appropriate to perform the following operation. Weld these two channels at a 45° angle from the bottom of the rail up to the underside of the truck body, at a body cross sill. If necessary, an appropriate length of 1/4" x 2" flat bar may be used to bridge between two or more body sills.

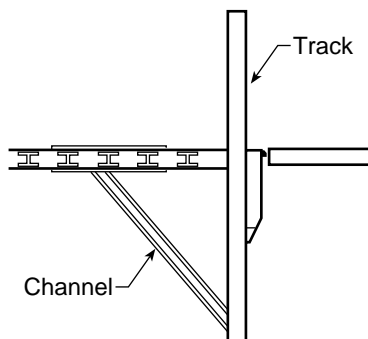

## 2.5 Special Adjustments for Above-Floor-Bed Lifts



Use this procedure with Above Floor Model liftgates. (AF suffix)

Your liftgate is preset to a bed height of 46".

If your bed height is greater than 46", contact Customer Service for additional chain links.

**STEP 1** Lower the platform to the ground.

**STEP 2** Remove housing cover by unfastening five (5) 1/4 X 20 bolts.

**STEP 3** While pressing the DOWN toggle on the control switch, force the hydraulic cylinder in until it is fully collapsed.

### Collapse Cylinder

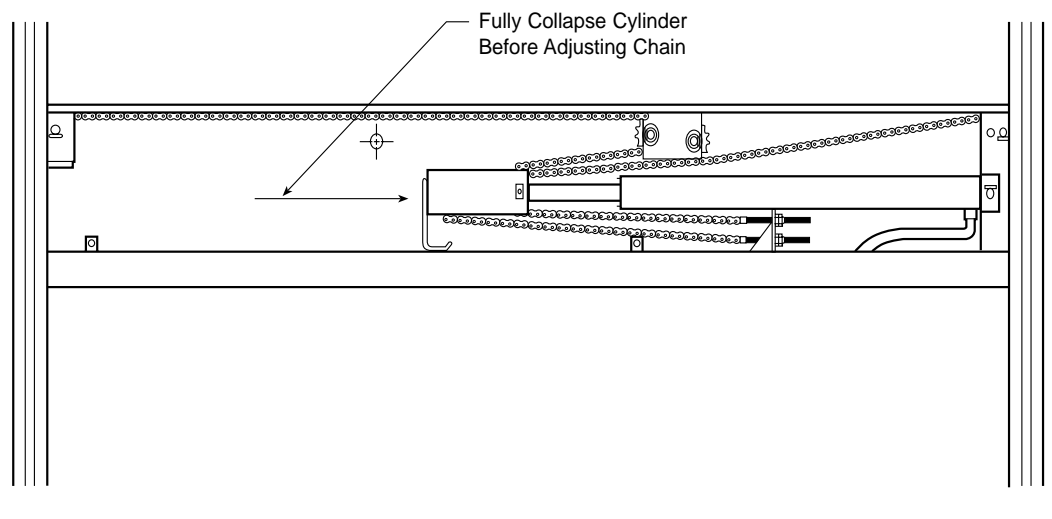



**WARNING**

Improperly secured master links may separate causing the load to fall, possibly leading to severe injury or even death.

**STEP 4** Disconnect top roller chain at adjusting bolt

**STEP 5** While disconnected, pull chain tight to remove all slack.

**STEP 6** Mark closest roller link to adjusting bolt



**STEP 7** Cut and remove connecting link. Clamp one of the sections of cotter pin type chain into a vise (be careful not to damage the chain). Use a hammer and a punch.

**Note:** A chain breaking tool may be used if one is available.

**Note:** "One" link unit consists of one connecting link and one roller link.

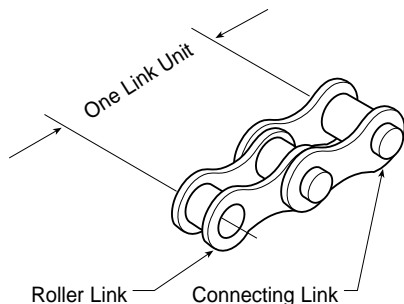

**STEP 8** Attach roller link to adjusting bolt using extra master link provided.

**STEP 9** Repeat steps 4 through 8 for bottom roller chain.

**STEP 10** Adjust the platform by loosening or tightening the adjuster nut.

**Note!** Call Customer Service if any parts are missing or defective.  
 USA: 800-289-1335  
 Canada: 416-421-7987

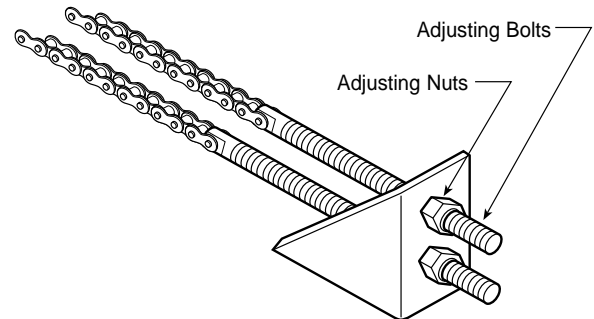

## 2.6 Install Remote Power Unit Box (GB30, HD30, HD40, Option 305)

If you are **NOT** installing a liftgate model GB30, HD30, HD40 or liftgate with Option 305 – Power Open and Close, proceed to Section 3 (Install Electrical Components).

### STEP 1

Position the power unit box underneath the truck body against cross members. The power unit must be mounted on the curb side of the body as close as possible to the rear of the body, ensuring that the supplied  $\frac{1}{2}$ " and  $\frac{1}{4}$ " high pressure hose assemblies will reach from the outlet of the pump to the inlet ports of the cylinder. The power unit box must not extend past the side of the truck body.

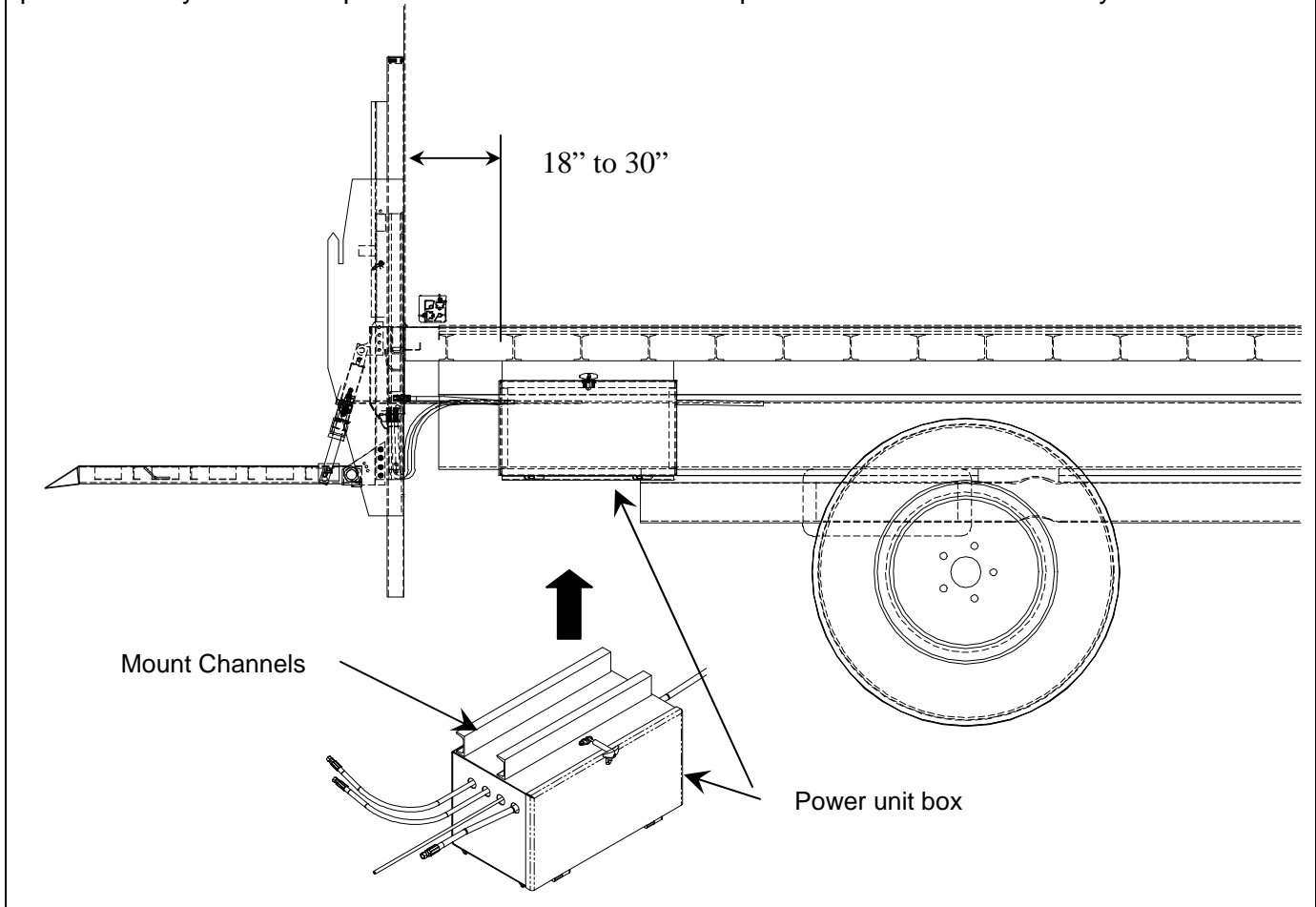

### STEP 2

With power unit box properly positioned weld the power unit box mount channels to cross members underneath the truck body with three  $\frac{1}{4}$ " x 2" fillets welds per channel.

**STEP 3**

Make all connections, both battery cable and control wires as per wiring diagrams below.

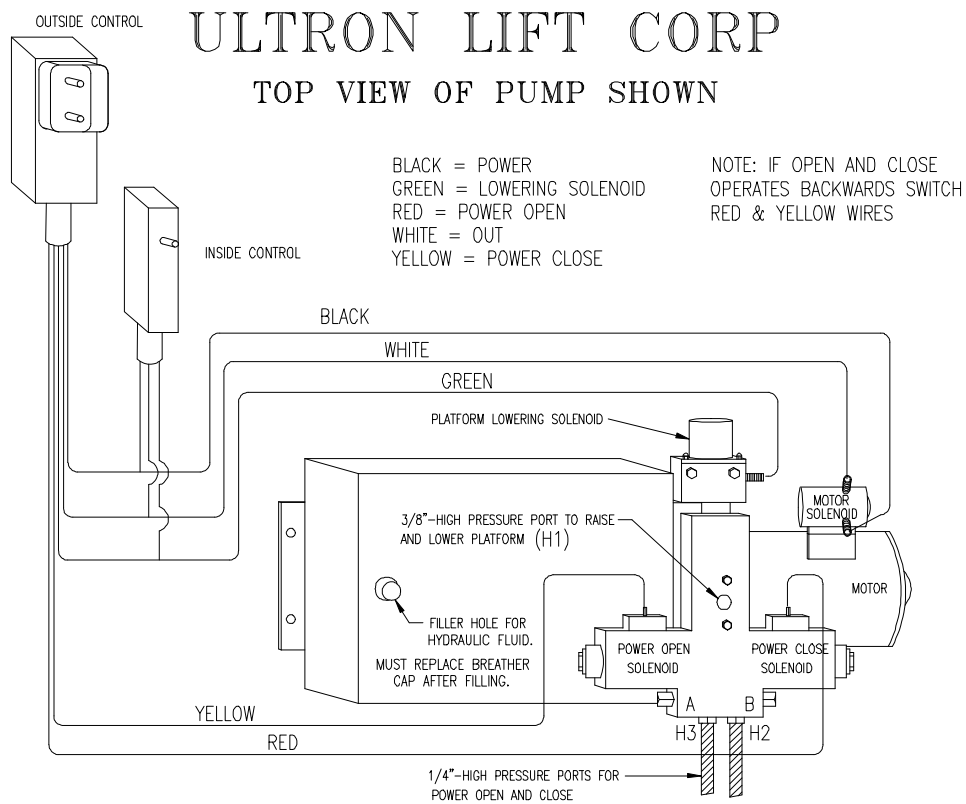
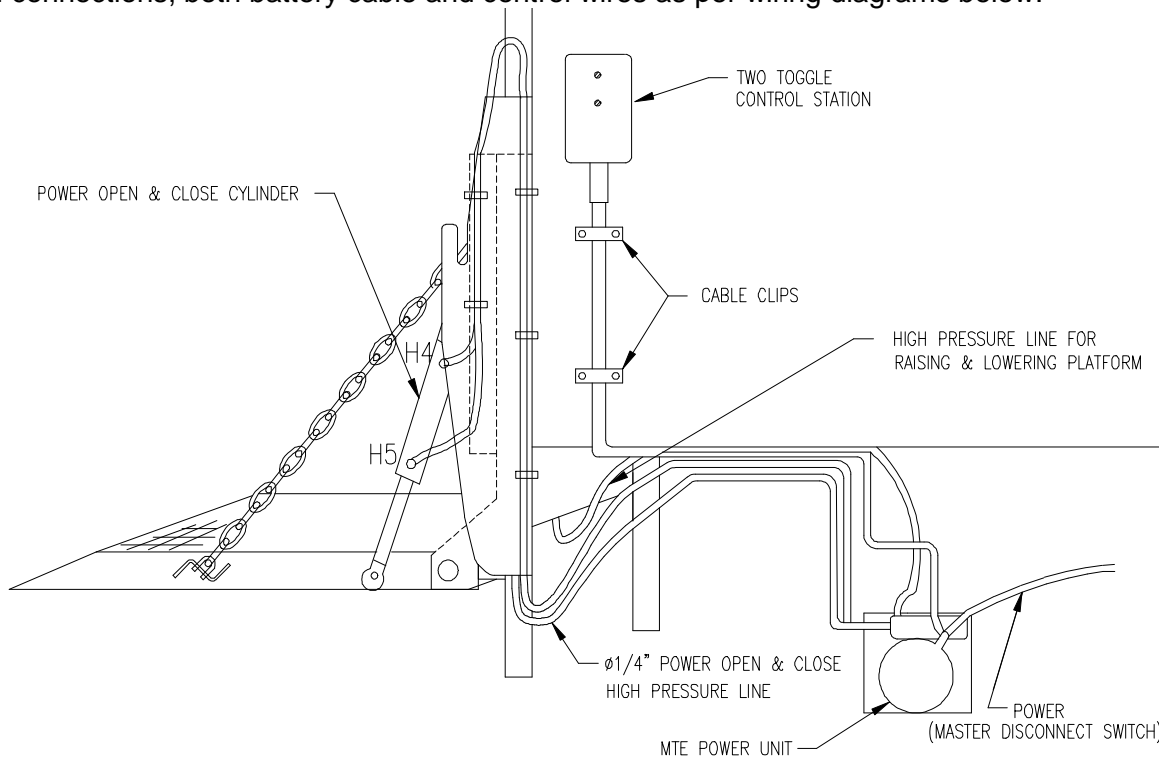

**STEP 4**

Attach the low pressure 3/16" return line from lift cylinder rod port to the barb fitting on top of the power unit tank. Trim excess tubing before connecting if needed.

**STEP 5**

Secure all hydraulic lines to body using cable clamps or cable ties.

**STEP 6**

Fasten switch cable to body using cable clips and self drilling screws.

**STEP 7**

Attach battery cable to the same motor solenoid terminal as the black wire in step 3.

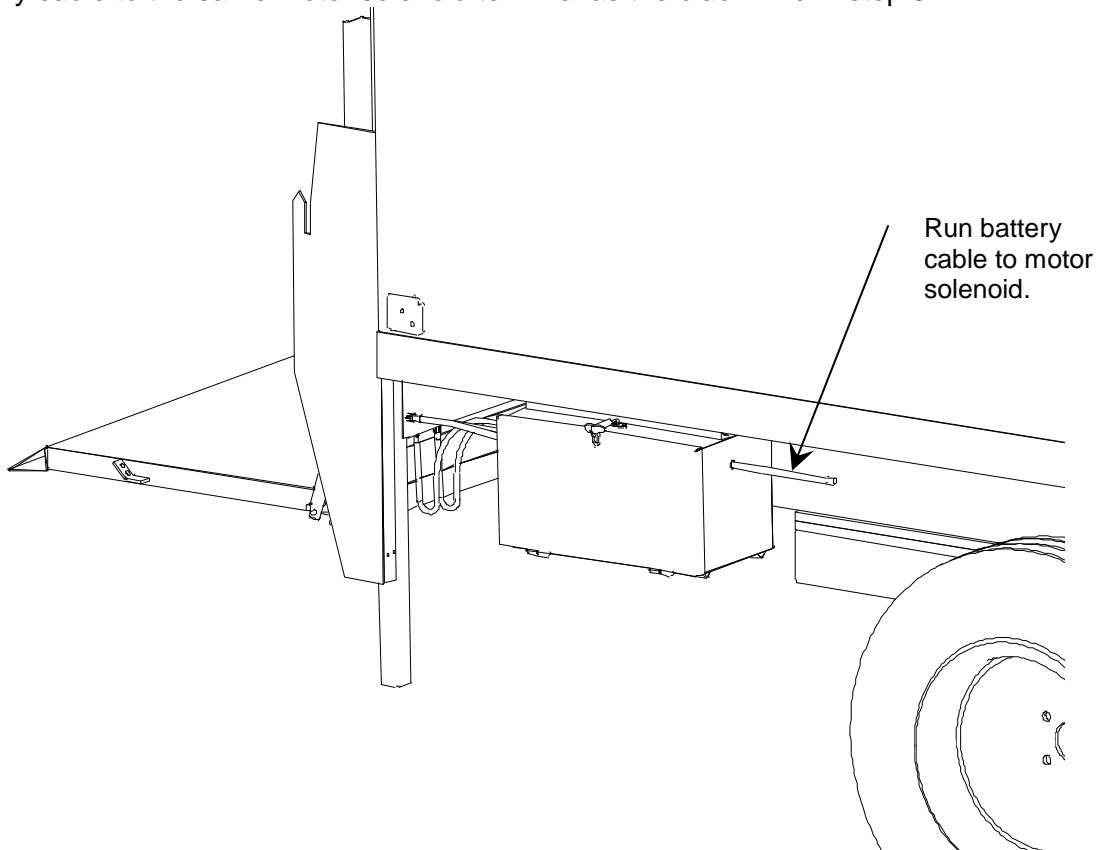

### 3. INSTALL ELECTRICAL COMPONENTS



#### WARNING

Do not attempt to install electrical components unless you are properly trained in truck electrical equipment. Improper installation of electrical components may result in severe personal injury or death.

#### 3.1 Install Master Disconnect Switch



Install the Master Disconnect Switch and the Circuit Breaker that you received with your DEL liftgate.

**If you use any other switch or circuit breaker, you will void your warranty.**

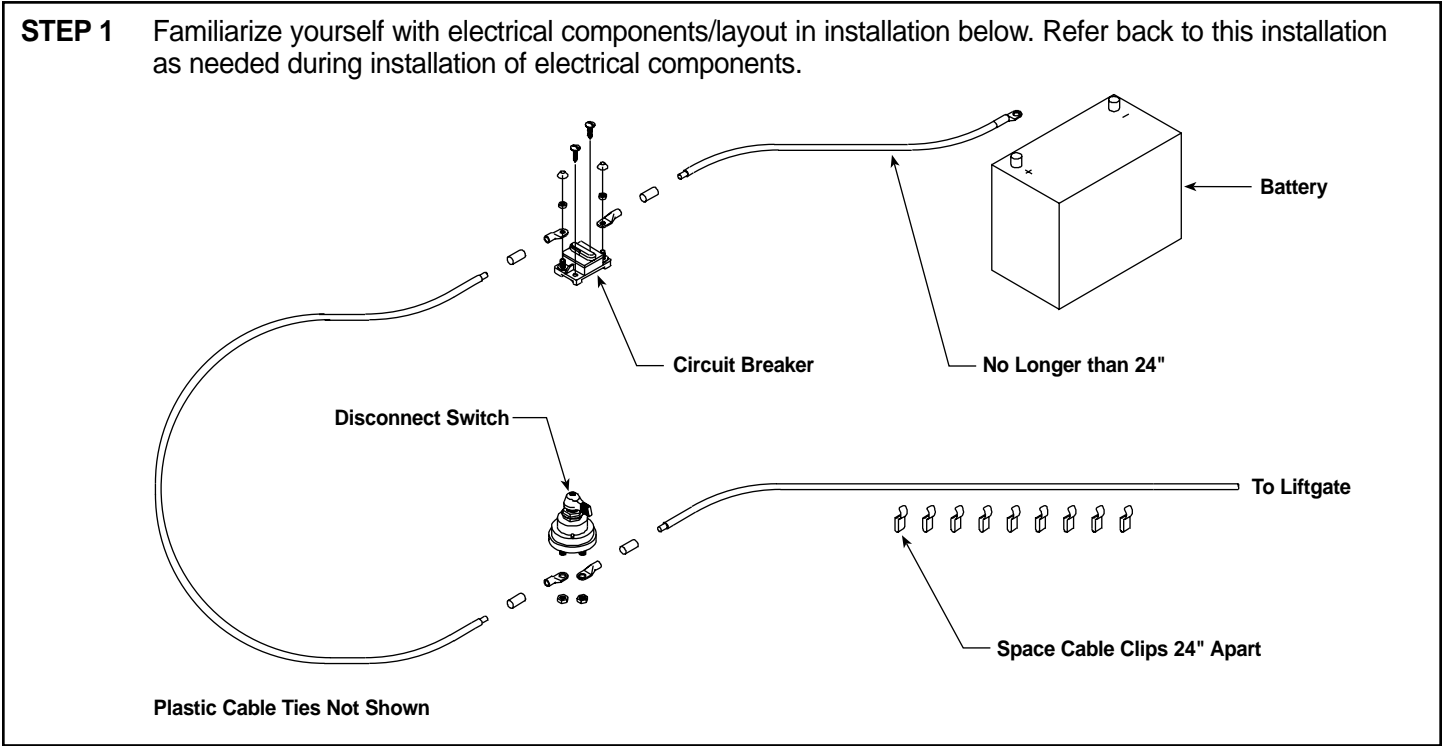

**STEP 2** Find a place in the cab to install the Master Disconnect Switch. The best location is:

- Accessible to the driver/operator
- and
- Secure from damage

**STEP 3** Drill one 3/4" hole in the floor.

**STEP 4** Remove the screw from the center of the handle on the Master Disconnect Switch.

**STEP 5** Unscrew the large nut and remove the lock washer from the top of the switch.

**STEP 6** Insert switch into hole from underneath the cab floor so the threaded part of the switch is visible.

**STEP 7** Put the cover plate over the visible part (threaded part) of the switch.

**STEP 8** Secure the nut and washer to the threaded part of the switch.

**STEP 9** Reattach handle and cover plate.  
**Note!** The handle and cover plate should be the only part of the switch visible.

**STEP 10** Run the battery cable from the liftgate to the terminals on the Master Disconnect Switch.  
**Note!** To avoid short circuits:  
Route the cable away from heat sources, moving parts, and possible road contact.  
Secure the cable under the truck every 24" with the plastic ties and wire clamps provided in the Electrical Component Kit.

**STEP 11** Determine how long the battery cable should be to reach the terminals and cut it to that length.  
**Note!** Measure before cutting!

**STEP 12** Strip battery cable casing back 1/2".

**STEP 13** Slide the shrink tube over the battery cable.

**STEP 14** Crimp the battery terminal provided to the stripped end of the cable.

**STEP 15** Slide the shrink tube into position centered over the terminal and battery cable seam.

**STEP 16** Heat the shrink tube until the tube is sealed against terminal and battery cable casing.

**STEP 17** Apply a protective coating of corrosion preventive compound to the connections.  
**Note!** Terminal connections may corrode prematurely unless you apply the corrosion preventive compound.

## 3.2 Install the Circuit Breaker

**STEP 1** Find a convenient location within 24" of the battery to install the Circuit Breaker. Location should be such that:

- Cable running from positive terminal of battery is no longer than 24".
- There is good protection against objects coming in contact with Circuit Breaker terminals and causing a short.
- There is easy access to the Circuit Breaker to reset it, when necessary.

**STEP 2** Use the Circuit Breaker as a guide to drill pilot holes for the 1/4" sheet metal screws provided.

**STEP 3** Screw the Circuit Breaker to the compartment wall.

**STEP 4** Measure how long the battery cable should be to reach from the unconnected terminal on the Master Disconnect Switch to the AUX terminal on the Circuit Breaker.

**STEP 5** Cut the battery cable to the correct length.  
**Note!** Measure before cutting!

**STEP 6** Run the battery cable from the unconnected terminal on the Master Disconnect Switch to the AUX terminal on the Circuit Breaker.

**Note!** To avoid short circuits:  
Route the cable away from heat sources, moving parts, and possible road contact.  
Secure the cable under the truck every 24" with the plastic ties and wire clamps provided in the Electrical Component Kit.

**STEP 7** Strip battery cable casing back 1/2".

**STEP 8** Slide the shrink tube over the battery cable.

**STEP 9** Crimp the battery terminal provided to the stripped end of the cable.

**STEP 10** Slide the shrink tube into position centered over the terminal and battery cable seam.

**STEP 11** Heat the shrink tube until the tube is sealed against terminal and battery cable casing.

**STEP 12** Apply a protective coating of corrosion preventive compound to the connections.

**Note!** Terminal connections may corrode prematurely unless you apply the corrosion preventive compound.

**STEP 13** Measure how long the battery cable should be to reach from the BAT terminal on the Circuit Breaker to the positive side of the battery.

**STEP 14** Cut the battery cable to the correct length.  
**Note!** Measure before cutting!

**STEP 15** Run the battery cable from the BAT terminal on the Circuit Breaker to the positive side of the battery.

**Note!** To avoid short circuits:

Route the cable away from heat sources, moving parts, and possible road contact.

Secure the cable under the truck every 24" with the plastic ties and wire clamps provided in the Electrical Component Kit.

**STEP 16** Strip battery cable casing back 1/2".

**STEP 17** Slide the shrink tube over the battery cable.

**STEP 18** Crimp the battery terminal provided to the stripped end of the cable.

**STEP 19** Slide the shrink tube into position centered over the terminal and battery cable seam.

**STEP 20** Heat the shrink tube until the tube is sealed against terminal and battery cable casing.

**STEP 21** Apply a protective coating of corrosion preventive compound to the connections.

**Note!** Terminal connections may corrode prematurely unless you apply the corrosion preventive compound.

**STEP 22** Connect the positive and the negative leads to the battery.

### 3.3 Secure The Cables

**STEP 1** Use the nylon ties included in your Electrical Component Kit to secure any cable running underneath the truck as detailed in Step 2 below.

**Note!** If the cable is not secured properly, the warranty is null and void.

**STEP 2** Secure the cable every 24", keeping it away from:

- Moving parts
- Heat sources (exhaust)
- Road

### 3.4 Wire Lights (Options 207-3 and 207-4 Only)



All lights must be installed in accordance with all applicable DOT and other state, provincial, and federal regulations.

**STEP 1** Using the **Wiring Schematic** as a guide, wire the mating plug and harness to the vehicle's wiring system.

**Wiring Schematic**

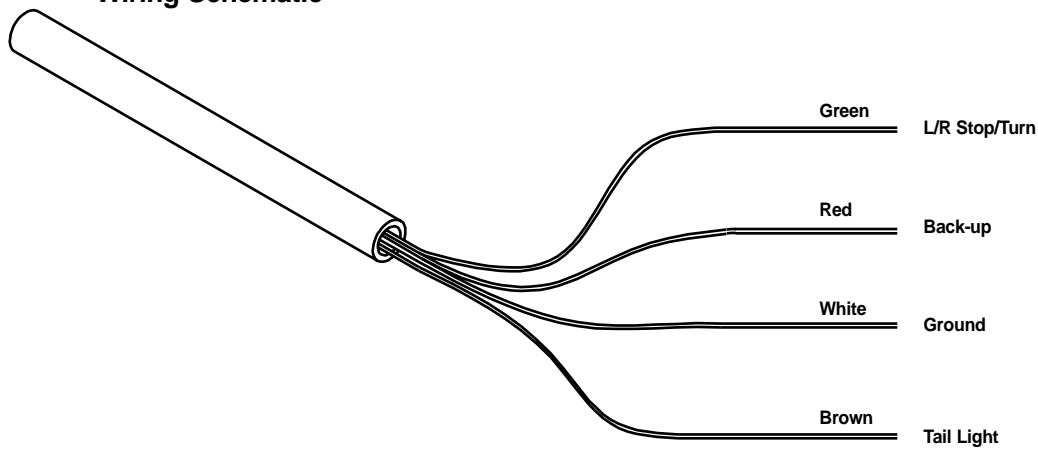

**STEP 2** Make sure all lights operate properly after wiring.

## 4. TEST THE LIFTGATE OPERATION

**STEP 1** Locate Operators Manual and follow instructions for liftgate operation.

**STEP 2** Run liftgate for four complete cycles.

# 5. COMPLETE THE INSTALLATION

## 5.1 Affix Warning Decals

**STEP 1** Apply the decals provided to their proper positions, following the figure below.

### Decal Placement

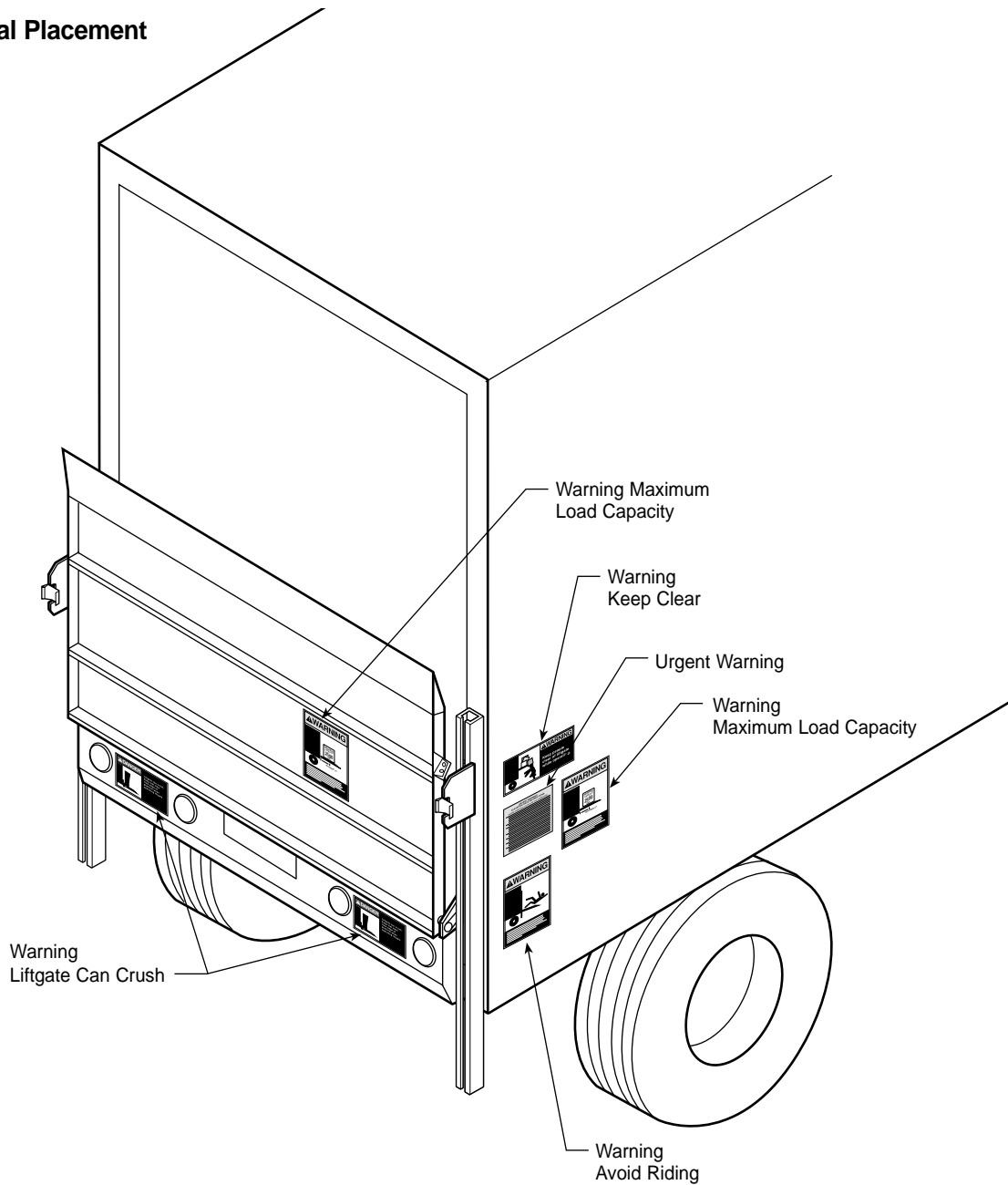

## 5.2 Operator's Manual

**STEP 1** Write the model number and serial number of the liftgate in the Operator's Manual.

**STEP 2** Ensure that the Operator's Manual is in the glove box of the truck.

**5.3 Final Test**

**STEP 1** Load the liftgate as shown in the **Load Lifting Capabilities Table** below, with load centered on the platform.

**Load Lifting Capabilities Table**

| DL Model               | Test Load<br>(full rated capacity) |
|------------------------|------------------------------------|
| DL12                   | 1250 lbs.                          |
| DL16, DS16, DT16, GB16 | 1600                               |
| DL20, DS20, DT20, GB20 | 2000                               |
| DL30, DS30, DT30, GB30 | 3000                               |
| HD40                   | 4000                               |

**STEP 2** Test the loaded liftgate following **Procedure 4.0: Test the Liftgate Operation**. Make sure you check the items shown in **Load-Testing Table** below.

**Load-Testing Table**

| WHAT TO CHECK   | POSSIBLE PROBLEMS  | SOLUTIONS   |
|---|--|---|
| Fasteners<br>Nuts<br>Bolts<br>Clevis pins<br>Cotter pins<br>Roller pins       | Loose Fasteners<br>Parts missing<br>Parts damaged                | Tighten Fasteners<br>Call Customer Service<br>for OEM parts.<br>USA: 800-289-1335<br>Canada: 416-421-7987 |
| Welds   | Cracked or broken welds  | Call Customer Service.<br>USA: 800-289-1335<br>Canada: 416-421-7987                                       |
| Hydraulic Leaks   | Tanks overfilled<br><br>Loose fitting or<br>loose hydraulic line | Make sure the tank is<br>not overfilled<br><br>Tighten loose fitting<br>or hydraulic line                 |
| Platform is level<br>with the floor of<br>the truck when<br>raised completely | Platform is not level.   | Level platform using<br>adjusting bolts.  |
| Any unusual<br>noise  | Various  | Call Customer Service.<br>USA: 800-289-1335<br>Canada: 416-421-7987                                       |

## 5.4 Inspect Your Installation and Document Your Inspection



### WARNING

Severe personal injury could result if you fail to check each of the following items.  
DO NOT USE the liftgate if any of the following points are not checked.

Call Customer Service if you have any questions.

USA: 800-289-1335

Canada: 416-421-7987

**NOTE** Installation is not complete if you have not checked and verified the items listed on the Inspection Sheet .

**Note!** Warranty is void if Inspection Sheet is not complete.

**STEP 1** Complete the **Inspection Sheet** on Page 34.

**STEP 2** Keep the completed **Inspection Sheet** on file at the facility where the installation is performed.

## Inspection Sheet

- \_\_\_ 1. Lifting bar and shipping frame are removed from the liftgate (See page 18).
- \_\_\_ 2. Pump reservoir is full to proper level when platform is fully lowered.  
(Automatic transmission fluid is recommended).
- \_\_\_ 3. All tack welds are now complete welds.
- \_\_\_ 4. Platform secures properly in its stowed position.
- \_\_\_ 5. Hydraulic components do not leak.
- \_\_\_ 6. Battery cable attached and clamped tight, but not pinched
- \_\_\_ 7. Lights wired properly and operational.
- \_\_\_ 8. License plate properly installed.
- \_\_\_ 9. All decals in place and legible.
- \_\_\_ 10. Battery and liftgate grounded to chassis.
- \_\_\_ 11. Platform opens properly.
- \_\_\_ 12. Platform travels up and down smoothly and freely, without any hesitation.
- \_\_\_ 13. Platform is level with the floor of the truck when raised completely (This does not apply to AF models).
- \_\_\_ 14. Platform rests on the ground when lowered completely.
- \_\_\_ 15. Toggle switch is secured properly.
- \_\_\_ 16. Cable to toggle switch is secured properly.
- \_\_\_ 17. Circuit Breaker installed.
- \_\_\_ 18. Master Disconnect Switch installed and operational.
- \_\_\_ 19. Tracks are cut and de-burred, if necessary.
- \_\_\_ 20. Reinforcement channels are placed before rear spring shackle.
- \_\_\_ 21. AF Models only: chain is adjusted according to Procedure 2.5.
- \_\_\_ 22. The liftgate's serial number and model number are written on the inside of the front cover of the Operator's Manual, in the space provided.
- \_\_\_ 23. Operator's Manual Kit is in the truck's glove box.
- \_\_\_ 24. Supervisor has demonstrated the Operating Instructions to the customer/driver.

### Inspection Information:

Completed by: \_\_\_\_\_  
(signature)

Name (please print): \_\_\_\_\_

Title: \_\_\_\_\_

Date: \_\_\_\_\_