



Aluminum platform - optional

Service Body Liftgates

SB Series™

Transforms your service body into a multi-purpose vehicle. Cargo is easily loaded into the payload area. An exclusive “above floor lift” option, raises your cargo to a maximum height of 46" from the ground. This is exclusively available from Ultron and is the best product for those needing to reach a dock height.

Key Features

- Railstyle design offers maximum stability
- Above floor lift option lifts to a maximum of 46" from ground
- Safer:
 - level-ride, greater load stability
 - fewer pinch points
 - anti-skid steel treadplate platform
- Chain and sprocket drive ensures smooth operation and eliminates costly cable replacement
- **Lifting capacity** - 1,250 and 1,600 lbs.
- **Applications** - service bodies and side mount on flat beds



Above floor lift - optional

Call 800-289-1335 in the U.S.
416-421-7987 in Canada

Visit our web site: www.ultronlift.com

Service Body Railgate Product Information

Clearance and Lift Dimensions

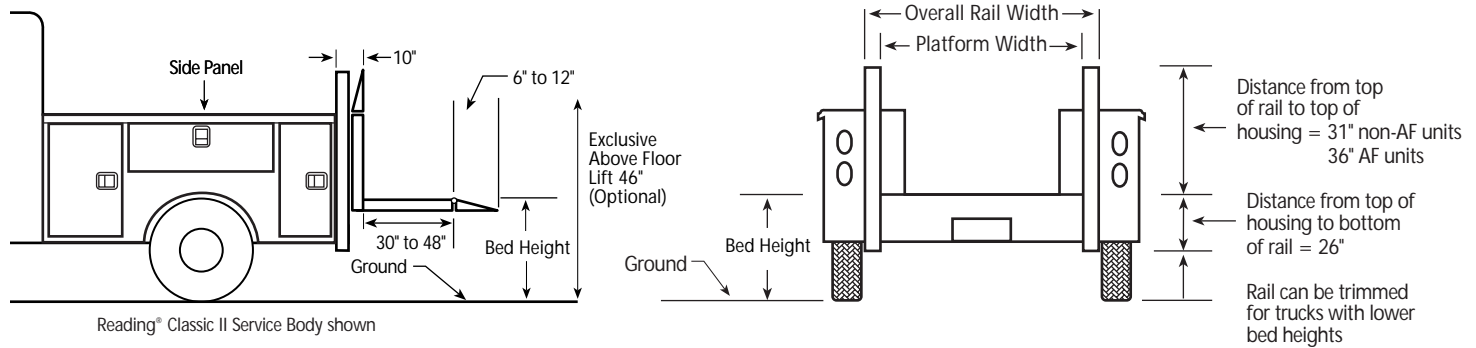

Specifications

| Model | Lifting Capacity (lbs.) | Bed Height Min-Max | Steel Platform Width x Depth (inches) | Aluminum Platform Width x Depth (inches) | Overall Rail Width | Shipping Weight (lbs) |
|---------------|-------------------------|--------------------|---------------------------------------|--|--------------------|-----------------------|
| SB126230 | 1,250 | 25"-46" | 57" x 30" + 6" | 57" x 30" + 6" | 62" | 310 |
| SB126230AF* | 1,250 | 25"-46" | 57" x 30" + 6" | 57" x 30" + 6" | 62" | 310 |
| SB126630 | 1,250 | 25"-46" | 61" x 30" + 6" | 61" x 30" + 6" | 66" | 350 |
| SB126630AF* | 1,250 | 25"-46" | 61" x 30" + 6" | 61" x 30" + 6" | 66" | 425 |
| SB166630 | 1,600 | 25"-46" | 61" x 30" + 6" | 61" x 30" + 6" | 66" | 360 |
| SB166630AF* | 1,600 | 25"-46" | 61" x 30" + 6" | 61" x 30" + 6" | 66" | 420 |
| SB166642 | 1,600 | 25"-46" | 61" x 42" + 6" | 61" x 42" + 6" | 66" | 385 |
| SB166642AF* | 1,600 | 25"-46" | 61" x 42" + 6" | 61" x 42" + 6" | 66" | 445 |
| PT166248AFV** | 1,600 | 25"-46" | N/A | 57" x 48" + 12" | 62" | 555 |
| PT166648AFV** | 1,600 | 25"-46" | N/A | 61" x 48" + 12" | 66" | 565 |

* Models with 46" above floor lift. Bed height maximum minus actual truck bed height = platform lift above floor

** Models with above floor lift and aluminum platform

Standard Features

- Three year warranty
- License plate recess
- Built-in toe deflector
- Master disconnect switch and 135 amp circuit breaker
- "Level ride" lift provides straight vertical platform movement for cargo stability unlike arcing motion of cable lift
- Weather sealed electric controls are easier and safer than mechanical controls
- Torsion bar assisted platform makes it easier to open and close
- Billboard cover for corporate graphics
- Pressure compensated flow control valve controls platform descent regardless of load weight

Popular Options

- Aluminum, galvanized, expanded metal or bar grating platform material
- Oversized ramp – fixed, hinged or with cart stop in aluminum or steel
- Non standard liftgates: deeper, narrower or wider platforms
- Remote hand held toggle switch control with 15 ft. coil cord
- Low maintenance value pak
- Hydraulic platform closing



Authorized Distributor

E-mail: info@ultronlift.com • Web: www.ultronlift.com

Ultron Lift Corp.
 190 Lewis Street • PO Box 6126
 Buffalo, NY 14240-6126 USA
 Phone: 800-289-1335
 716-853-7994
 Fax: 716-854-5424

Ultron Lift Inc.
Les Hayons Ultron Inc.
 12 Industrial Street
 Toronto, ON M4G 1Y9 Canada
 Phone: 416-421-7987
 Fax: 416-421-7927